

PIPE & TUBE

WELLGROW INDUSTRIES CORP.



- ▲ Pipe
- ▲ Square Tube
- ▲ Rectangular Tube
- ▲ Mechanical Tube
- ▲ Tube for Boiler & Heat-exchanger
- ▲ Sanitary Tube

STAINLESS STEEL AND CARBON STEEL PIPES

**Stainless Steel Pipe and Carbon Steel Pipe
ASTM A312, A778, A53, A106, API 5L**

Nominal Pipe Size Inch	Outside Diameter		Wall thickness: mm																
	in	mm	SCH 5S	SCH 10S	SCH 10	SCH 20	SCH 30	SCH 40S / STD	SCH 40	SCH 60	SCH XS	SCH 80S	SCH 80	SCH 100	SCH 120	SCH 140	SCH 160	SCH XXS	
1/8	0.405	10.29		1.24	1.24			1.73	1.73	2.20	2.41	2.41	2.41				3.15	4.83	
1/4	0.540	13.72		1.65	1.65			1.85	2.24	2.24	2.40	3.02	3.02	3.02				3.68	6.05
3/8	0.675	17.15		1.65	1.65			1.85	2.31	2.31	2.80	3.2	3.20	3.20				4.01	6.40
1/2	0.840	21.34	1.65	2.11	2.11			2.41	2.77	2.77	3.20	3.73	3.73	3.73				4.78	7.47
3/4	1.050	26.67	1.65	2.11	2.11			2.41	2.87	2.87	3.40	3.91	3.91	3.91				5.56	7.82
1	1.315	33.40	1.65	2.77	2.77			2.90	3.38	3.38	3.90	4.55	4.55	4.55				6.35	9.09
1 1/4	1.660	42.16	1.65	2.77	2.77			2.97	3.56	3.56	4.50	4.85	4.85	4.85				6.35	9.7
1 1/2	1.900	48.26	1.65	2.77	2.77			3.18	3.68	3.68	4.50	5.08	5.08	5.08				7.14	10.15
2	2.375	60.33	1.65	2.77	2.77			3.18	3.91	3.91	4.90	5.54	5.54	5.54				8.74	11.07
2 1/2	2.875	73.03	2.11	3.05	3.05			4.78	5.16	5.16	6.00	7.01	7.01	7.01				9.53	14.02
3	3.500	88.90	2.11	3.05	3.05			4.78	5.49	5.49	6.60	7.62	7.62	7.62				11.13	15.24
3 1/2	4.000	101.60	2.11	3.05	3.05			4.78	5.74	5.74	7.00	8.08	8.08	8.08				-	-
4	4.500	114.30	2.11	3.05	3.05			4.78	6.02	6.02	7.10	8.56	8.56	8.56		11.13		13.49	17.12
5	5.563	141.30	2.77	3.40	3.40				6.55	6.55	8.10	9.53	9.53	9.53		12.7		15.88	19.05
6	6.625	168.28	2.77	3.40	3.40				7.11	7.11	9.30	10.97	10.97	10.97		14.27		18.26	21.95
8	8.625	219.08	2.77	3.76	3.76	6.35	7.04	8.18	8.18	10.31	12.7	12.7	12.7	15.09	18.26	20.62	23.01	22.23	
10	10.750	273.05	3.40	4.19	4.19	6.35	7.80	9.27	9.27	12.7	12.7	12.7	15.09	18.26	21.44	25.4	28.58	25.40	
12	12.750	323.85	3.96	4.57	4.57	6.35	8.38	9.53	10.31	14.27	12.7	12.7	17.48	21.44	25.4	28.58	33.32	25.40	

Large Diameter Stainless Steel Pipe and Carbon Steel Pipe ASTM A312, A358, A53, A106, API 5L

Nominal Pipe Size Inch	Outside Diameter		Wall thickness: mm														
	in	mm	SCH 5S	SCH 10S	SCH 10	SCH 20	SCH 30	SCH STD	SCH 40	SCH 60	SCH XS	SCH 80	SCH 100	SCH 120	SCH 140	SCH 160	SCH XXS
14	14.000	355.60	3.96	4.78	6.35	7.92	9.53	9.53	11.13	15.09	12.7	19.05	23.83	27.79	31.75	35.71	35.71
16	16.000	406.40	4.19	4.78	6.35	7.92	9.53	9.53	12.7	16.66	12.7	21.44	26.19	30.96	36.53	40.49	40.49
18	18.000	457.20	4.19	7.78	6.35	7.92	11.13	9.53	14.27	19.05	12.7	23.88	29.36	34.93	39.67	45.24	45.24
20	20.000	508.00	4.78	5.54	6.35	9.53	12.7	9.53	15.09	20.62	12.7	26.19	32.54	38.1	44.45	50.01	50.01
22	22.000	558.80	4.78	5.54	6.35	9.53	12.7	9.53	-	22.23	12.7	28.58	34.93	41.28	47.63	53.98	53.97
24	24.000	609.60	5.54	6.35	6.35	9.53	14.27	9.53	17.48	24.61	12.7	30.96	38.89	46.02	52.37	59.54	59.54
26	26.000	660.00			7.92	12.7	-	9.53	-		12.7						
28	28.000	711.20			7.92	12.7	15.88	9.53	-		12.7						
30	30.000	762.00	6.35	7.92	7.92	12.7	15.88	9.53	-		12.7						
32	32.000	812.80			7.92	12.7	15.88	9.53	17.48		12.7						
34	34.000	863.60			7.92	12.7	15.88	9.53	17.48		12.7						
36	36.000	914.40			7.92	12.7	15.88	9.53	19.05		12.7						
38	38.000	965.20						9.53			12.7						
40	40.000	1016.00						9.53			12.7						
42	42.000	1066.80						9.53			12.7						
44	44.000	1117.60						9.53			12.7						
46	46.000	1168.40						9.53			12.7						
48	48.000	1219.20						9.53			12.7						
52	52.000	1321.00						9.53			12.7						
56	56.000	1422.00						9.53			12.7						
60	60.000	1524.00						9.53			12.7						
72	72.000	1829.00						9.53			12.7						

STAINLESS STEEL TUBES

Stainless Steel Square Tube
ASTM A554, CNS 5802

Outside Diameter mm \ Thickness mm	0.7	0.8	0.9	1.0	1.2	1.5	2.0	3.0
12.7x12.7								
15.9x15.9								
18.0x18.0								
19.0x19.0								
20.0x20.0								
25.0x25.0								
30.0x30.0								
31.8x31.8								
38.1x38.1								
40.0x40.0								
50.8x50.8								
60.0x60.0								
70.0x70.0								
80.0x80.0								
90.0x90.0								
100.0x100.0								

Stainless Steel Rectangular Tube
ASTM A554, CNS 5802

Outside Diameter mm \ Thickness mm	0.9	1.0	1.2	1.5	2.0	3.0
10x20						
13x26						
15x30						
20x40						
25x50						
25.4x38.1						
30x60						
40x80						
45x95						
50x100						

Stainless Steel Mechanical Tube
ASTM A554, CNS 5802

Outside Diameter mm \ Thickness mm	0.7	0.8	0.9	1.0	1.2	1.5	2.0	3.0
12.7								
15.9								
19.0								
22.2								
25.4								
28.6								
31.8								
38.1								
50.8								
63.5								
76.2								
88.9								
101.6								
114.3								

Stainless Steel Tube for Boiler & Heat-exchanger

ASTM A249, A269, JIS G3463, CNS 7383

Outside Diameter mm \ Thickness mm	1.6	2.0	2.3	2.6	2.9	3.2	3.5	4.0	3.5	5.0
21.7										
25.4										
27.2										
31.8										
34.0										
38.1										
42.7										
48.6										
50.8										
60.3										
63.5										
76.2										
88.9										
101.6										
114.3										
139.8										

Stainless Steel Sanitary Tube

ASTM A270

Outside Diameter mm \ Thickness mm	1.0	1.2	1.25	1.5	1.6	1.65	2.0	2.1
12.7								
19.05								
25.0								
25.4								
32.0								
38.0								
38.1								
40.0								
50.8								
51.0								
52.0								
63.5								
70.0								
76.2								
101.6								
104.0								

MANUFACTURING PROCESS

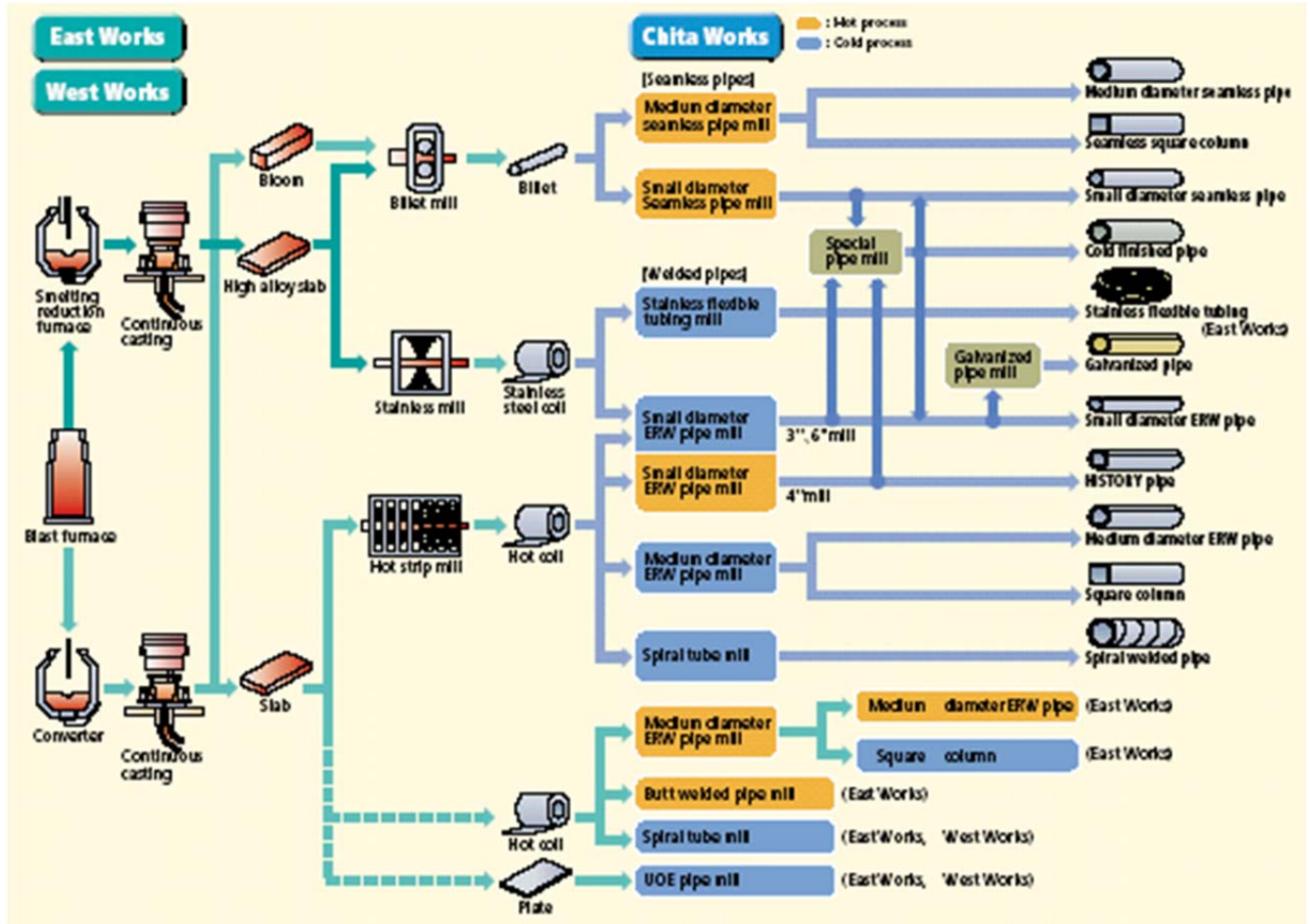

ELECTRIC RESISTANCE WELD PIPE (ERW)

Cold finished pipe made by a series of operations in which the flat rolled material is cold shaped into tubular form and welded at the seam by the application of pressure and heat. The heat is generated at the seam by the resistance to the flow of electric current applied through electrical contacts or an induction coil.

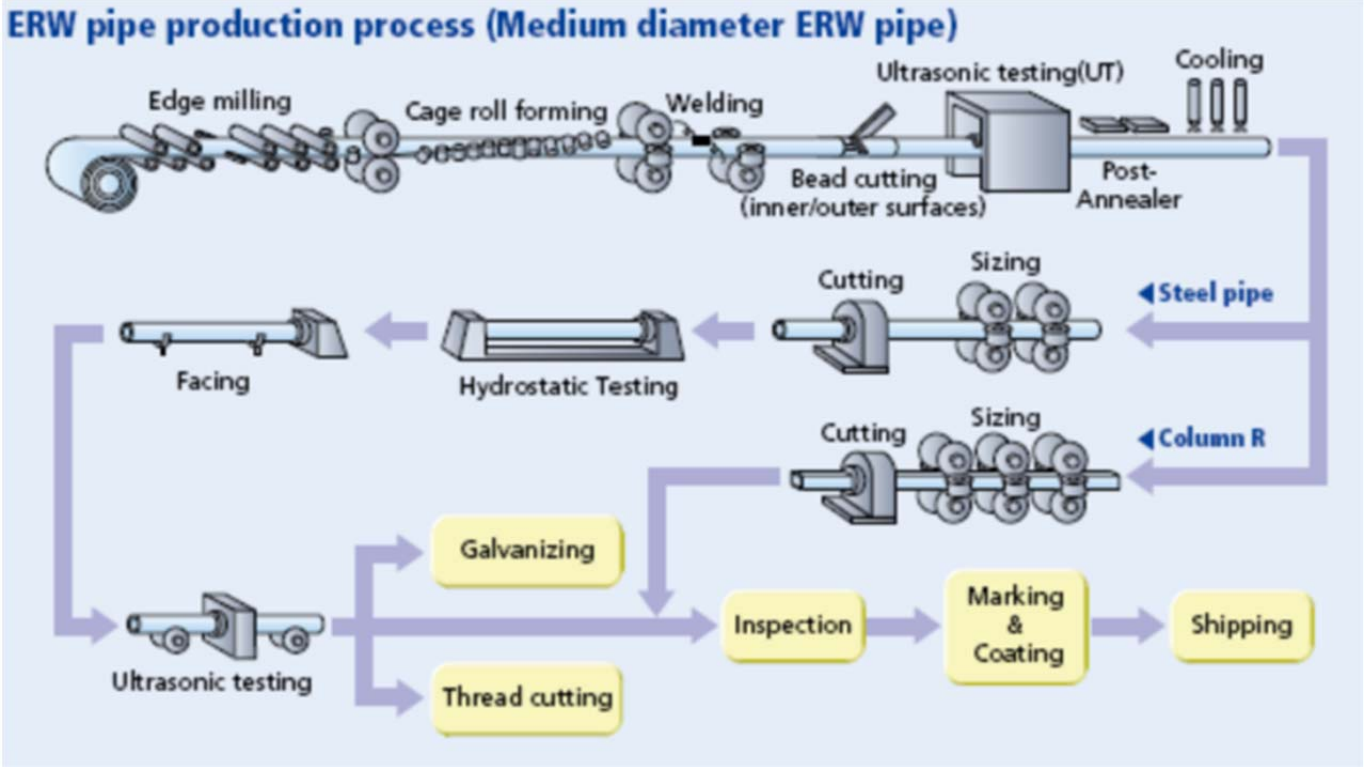

SEAMLESS PIPE

Hot finished pipe made from a reheated billet which is forged into a bottle shape, elongated and subsequently stretched over a mandrel bar by pushing through a series of roller dies. After reheating, reducing rolls give it its final dimensions.

