

VKGF14 Purged Knife Gate Valve With Double Cylinders

Feature

Connection Rating:

JIS 5K JIS 10K JIS 7.5K

ANSI 150#

DIN PN10 PN16

MSS-SP81 Test Standard:

Body Test: 11kg/cm² (Water)

Seat Test: 2.8kg/cm² (Water)

Leakage: 400 cc/per in. min.

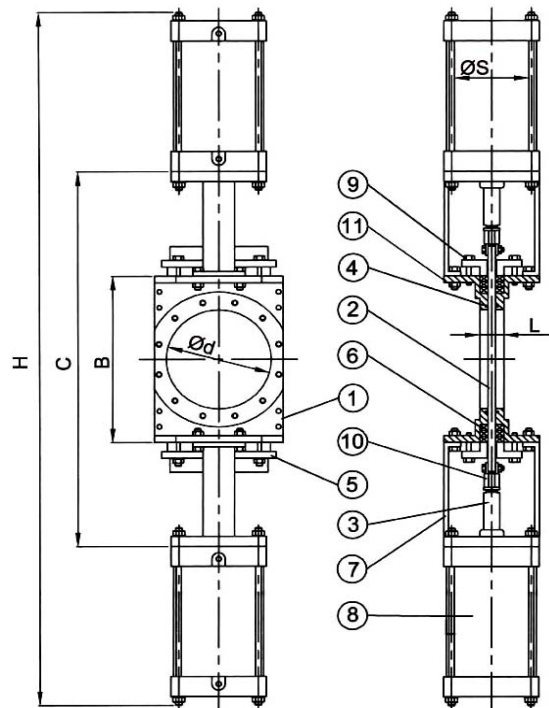

Temperature

MATERIAL	TEM. RANGE
ASBESTOS + PTFE	-50°C ~ 550°C
SILICON	-20°C ~ 150°C
VITON	-20°C ~ 250°C
TEFLON	-30°C ~ 150°C
NON ASBESTOS	-50°C ~ 550°C

Material Option

	BODY	PLATE	SEAT	GLAND PACKING
MATERIAL	FC WCB SCS13 SCS14 SCS16	SUS304 SUS316 SUS304L SUS316L	MET'L	NON-ASB+PTFE ASB ASB+PTFE NON ASBESTOS

Dimension

SIZE	Ød	L	B	C	H	ØS
4"	100	50	300	590	960	100
5"	120	50	325	640	1030	150
6"	150	60	370	720	1130	150
8"	200	60	450	870	1350	180
10"	250	70	550	1020	1560	200
12"	300	70	600	1120	1700	215
14"	350	70	700	1290	1990	250
16"	400	90	800	1580	2330	250
18"	450	110	900	1730	2530	300
20"	500	110	1000	2000	2890	300

Material List

NO.	PART NAME	MATERIAL
1	BODY	FCD/CF8/CF8M
2	PLATE	SUS304 '316
3	STEM	SS41+HCr
4	SEAT	METAL
5	GLAND	FC. CF8
6	GLAND PACKING	ASB NON-ASB
7	YOKE	FC FCD
8	ACTUATOR	AL ALLOYS.FC
9	BOLT NUT	MILD STEEL
10	CONNECTOR	SUS304
11	NUT	MILD STEEL