

VKGF12 Pneumatic Sealed Knife Gate Valve

Feature

Connection Rating:

JIS 5K JIS 10K JIS 7.5K

ANSI 150#

DIN PN10 PN16

MSS-SP81 Test Standard:

Body Test: 11kg/cm² (Water)

Seat Test: 2.8kg/cm² (Water)

Leakage: 4 cc/per in. min.

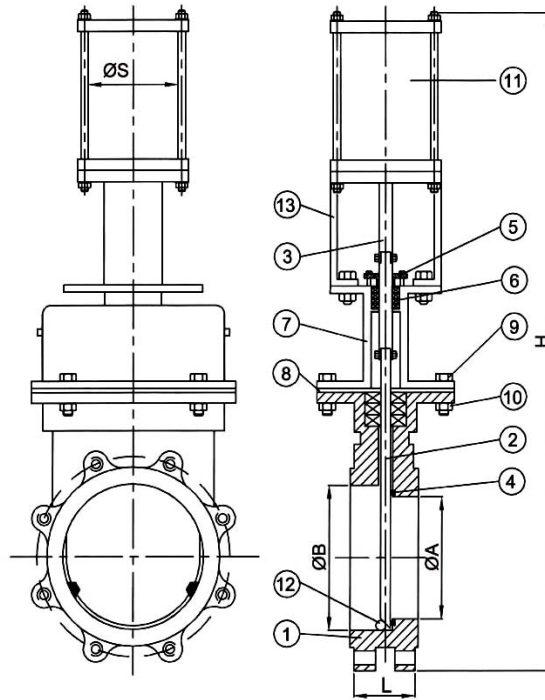

WELGROW

Temperature

MATERIAL	TEM. RANGE
ASBESTOS + PTFE	-50°C ~ 550°C
SILICON	-20°C ~ 150°C
VITON	-20°C ~ 250°C
TEFLON	-30°C ~ 150°C
NON ASBESTOS	-50°C ~ 550°C

Material Option

	BODY	PLATE	SEAT	GLAND PACKING
MATERIAL	FC	SUS304	TEFLON	NON-ASB+PTFE
	WCB	SUS316	METAL	ASB
	SCS13	SUS304L	VITON	ASB+PTFE
	SCS14	SUS316L	EPDM	TEFLON
	SCS16			NON ASBESTOS

Dimension

SIZE	L	ØA	ØB	ØS	H
4"	51	98	122	80	950
5"	57	123	146	125	1150
6"	57	150	175	125	1330
8"	70	195	225	150	1550
10"	70	250	275	180	1700
12"	76	300	325	200	1900
14"	76	350	375	250	2200
16"	89	400	430	250	2500
18"	89	435	475	250	2700
20"	114	480	515	300	2900

Material List

NO.	PART NAME	MATERIAL
1	BODY	CF8
2	PLATE	SUS304
3	STEM	SS41+HCr
4	SEAT	PTFE
5	GLAND	SUS304
6	GLAND PACKING	PTFE
7	COVER	CF8
8	PLATE	BC-6, AL ALLOY
9	BOLT	SUS304
10	NUT	SUS304
11	ACTUATOR	AL ALLOYS.FC
12	GUIDE	SUS304
13	YOKE	FCD