

VKGF09 Manual Square Knife Gate Valve

Feature

Connection Rating:

JIS 5K JIS 10K JIS 7.5K

ANSI 150#

DIN PN10 PN16

MSS-SP81 Test Standard:

Body Test: 11kg/cm² (Water)

Seat Test: 2.8kg/cm² (Water)

Leakage: 4 cc/ per in. min.

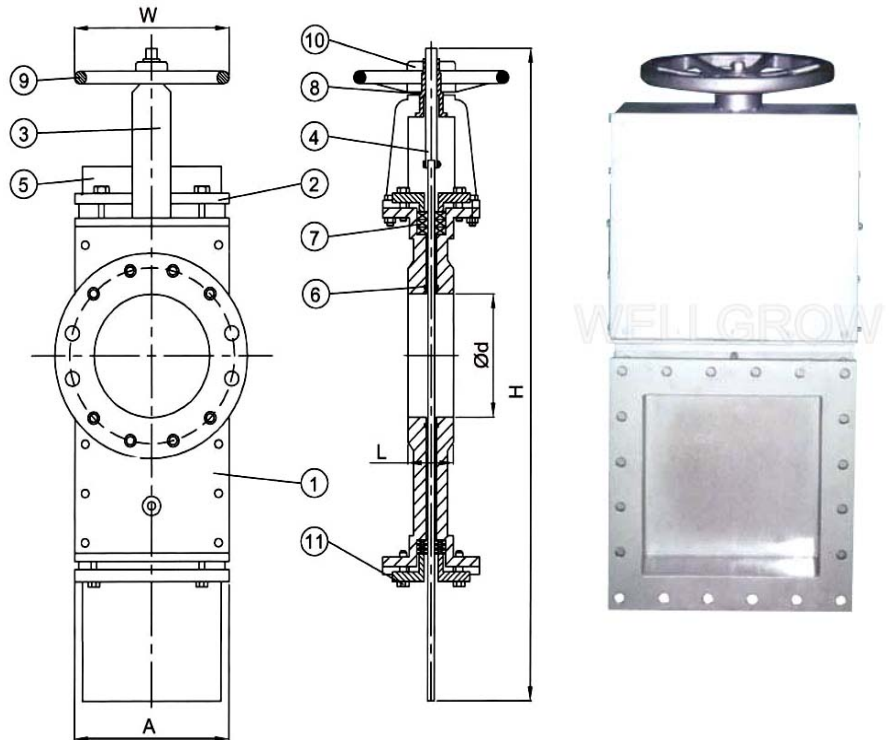

Temperature

MATERIAL	TEM. RANGE
ASBESTOS + PTFE	-50°C ~ 550°C
SILICON	-20°C ~ 150°C
VITON	-20°C ~ 250°C
TEFLON	-30°C ~ 150°C
NON ASBESTOS	-50°C ~ 550°C

Material Option

	BODY	PLATE	SEAT	GLAND PACKING
MATERIAL	CF8 CF8M CF3M FC FCD	SUS304 SUS316 SUS304L SUS316L	TEFLON METAL VITON EPDM	NON-ASB+PTFE ASB ASB+PTFE TEFLON NON ASBESTOS

Dimension

SIZE	L	A	Ød	W	H
4"	50	170	95	220	760
5"	50	200	122	290	870
6"	60	225	140	290	980
8"	60	275	188	385	1220
10"	70	330	240	385	1410
12"	70	390	293	400	1635
14"	70	430	320	400	1930
16"	90	495	360	500	2200
18"	90	600	430	500	2450
20"	110	620	490	500	2575
24"	110	650	545	500	2750

Material List

NO.	PART NAME	MATERIAL
1	BODY	FC/SUS304
2	GRAND	FC/SUS304
3	YOKE	FC/FCD
4	STEM	SUS410/304
5	PLATE	SUS304/316
6	SEAT	PTFE
7	PACKING	ASB NON-ASB
8	YOKE SLEEVE	BRONZE
9	HAND WHEEL	FC
10	NUT	FC
11	BOLT	MILD STEEL