

VKGF08 Pneumatic Sealed Slide Knife Gate Valve

Feature

Connection Rating:

JIS 5K JIS 10K JIS 7.5K

ANSI 150#

DIN PN10 PN16

MSS-SP81 Test Standard:

Body Test: 11kg/cm² (Water)

Seat Test: 2.8kg/cm² (Water)

Leakage: 4 cc/ per in. min.

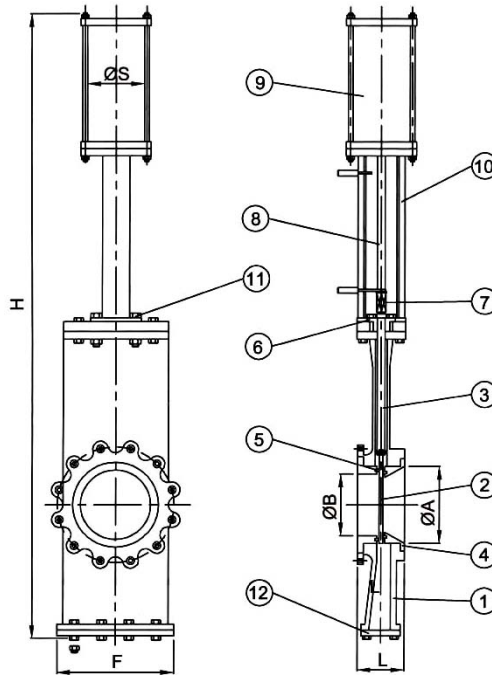

Temperature

MATERIAL	TEM. RANGE
ASBESTOS + PTFE	-50°C ~ 550°C
SILICON	-20°C ~ 150°C
VITON	-20°C ~ 250°C
TEFLON	-30°C ~ 150°C
NON ASBESTOS	-50°C ~ 550°C

Material Option

	BODY	PLATE	SEAT	GLAND PACKING
MATERIAL	SCS13 SCS14 AL	SUS304 SUS316 SUS304L SUS316L	TEFLON METAL VITON NBR	ASBESTOS+PTFE TEFLON NON ASBESTOS

Dimension

SIZE	L	ØA	ØB	F	L	ØS
2"	940	50	50	152	120	63
2-1/2"	990	65	65	180	120	63
3"	1050	90	90	190	120	80
4"	1200	116	116	230	120	80
5"	1350	145	145	255	120	125
6"	1500	170	170	280	120	125
8"	1700	221	221	345	150	150
10"	1900	276	276	400	150	180
12"	2200	325	325	480	150	200

Material List

NO.	PART NAME	MATERIAL
1	BODY	CF8
2	PLATE	SUS304
3	STEM	SUS304
4	GUIDE PLATE	CF8
5	SEAT	PTFE
6	GLAND	CF8
7	CONNECTORVER	SUS304
8	STEM	SS41 + HCr
9	ACTUATOR	ALUMINUM ALLOYS FC
10	YOKE	FCD / WCB
11	NUT	SUS304
12	COVER	CF8