

**VKGF05 Electric Operated Knife Gate Valve**

**Feature**

Connection Rating:

JIS 5K JIS 10K JIS 7.5K

ANSI 150LB

DIN PN10 PN16

MSS-SP81 Test Standard:

Body Test: 11kg/cm<sup>2</sup> (Water)

Seat Test: 2.8kg/cm<sup>2</sup> (Water)

Leakage: 4 cc/ per in. min.

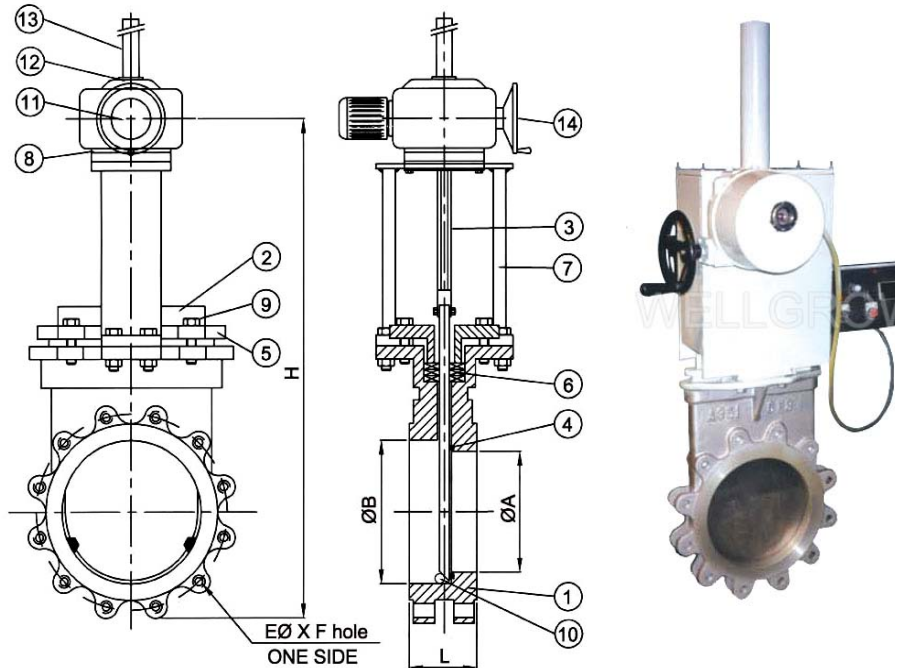

**Temperature**

| MATERIAL        | TEM. RANGE    |
|-----------------|---------------|
| ASBESTOS + PTFE | -50°C ~ 550°C |
| SILICON         | -20°C ~ 150°C |
| VITON           | -20°C ~ 250°C |
| TEFLON          | -30°C ~ 150°C |
| NON ASBESTOS    | -50°C ~ 550°C |

**Material Option**

|          | BODY | PLATE   | SEAT   | GLAND PACKING          |
|----------|------|---------|--------|------------------------|
| MATERIAL | CF8  | SUS304  | TEFLON | NON-ASB+PTFE           |
|          | CF8M | SUS316  | METAL  | ASB                    |
|          | CF3M | SUS304L | VITON  | ASB+PTFE               |
|          | FC   | SUS316L | EPDM   | TEFLON<br>NON ASBESTOS |

**Dimension**

| SIZE   | L   | ØA  | ØB  | H    |
|--------|-----|-----|-----|------|
| 2"     | 48  | 42  | 64  | 420  |
| 2-1/2" | 51  | 57  | 80  | 430  |
| 3"     | 51  | 72  | 95  | 430  |
| 4"     | 51  | 95  | 120 | 520  |
| 5"     | 57  | 125 | 148 | 640  |
| 6"     | 57  | 150 | 175 | 680  |
| 8"     | 70  | 195 | 222 | 780  |
| 10"    | 70  | 250 | 275 | 950  |
| 12"    | 76  | 300 | 325 | 1150 |
| 14"    | 76  | 350 | 375 | 1230 |
| 16"    | 89  | 400 | 430 | 1420 |
| 18"    | 89  | 435 | 475 | 1600 |
| 20"    | 114 | 480 | 515 | 1700 |
| 24"    | 114 | 580 | 620 | 1970 |

**Material List**

| NO. | PART NAME     | MATERIAL            |
|-----|---------------|---------------------|
| 1   | BODY          | CF8.CF8M.CF3M.FC    |
| 2   | PLATE         | SUS304.316.316L     |
| 3   | STEM          | SUS410.304.316.316L |
| 4   | SEAT          | TEFLON.EPDM         |
| 5   | GLAND         | SUS304              |
| 6   | GLAND PACKING | ASB ; TEFLON        |
| 7   | YOKE          | SS400               |
| 8   | YOKE SLEEVE   | DUCTILE IRON        |
| 9   | BOLT NUT      | SUS304              |
| 10  | PAWLS         | SUS304.316.317      |
| 11  | GEAR          | SS41                |
| 12  | MOTOR         | AL ALLOY            |
| 13  | TUBE          | CARBON STEEL        |
| 14  | HAND WHEEL    | CAST IRON           |