

VKGF02 Manual Stainless Steel Knife Gate Valve

Feature

Connection Rating:

JIS 5K JIS 10K JIS 7.5K

ANSI 150#

DIN PN10 PN16

MSS-SP81 Test Standard:

Body Test: 11kg/cm² (Water)

Seat Test: 2.8kg/cm² (Water)

Leakage: 4 cc/ per in. min.

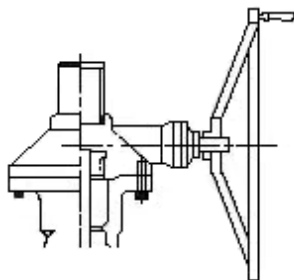

available with gear operator

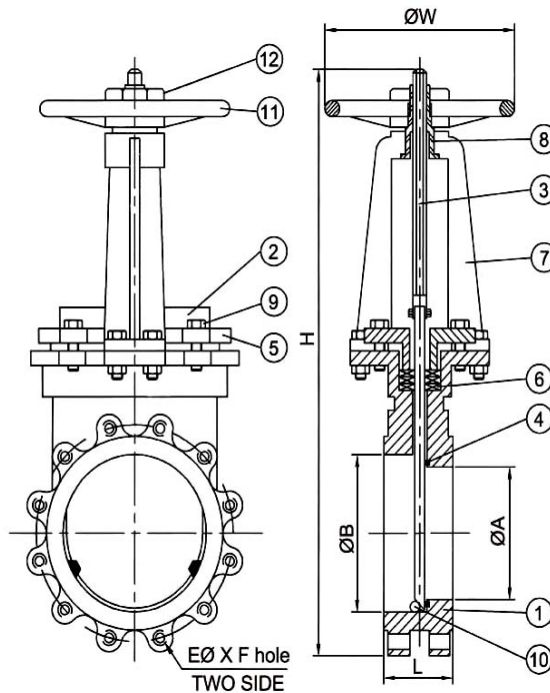

Temperature

MATERIAL	TEM. RANGE
ASBESTOS + PTFE	-50°C ~ 550°C
SILICON	-20°C ~ 150°C
VITON	-20°C ~ 250°C
TEFLON	-30°C ~ 150°C
NON ASBESTOS	-50°C ~ 550°C

Material Option

	BODY	PLATE	SEAT	GLAND PACKING
MATERIAL	CF8 CF8M CF3M	SUS304 SUS316 SUS304L SUS316L	TEFLON METAL VITON EPDM	NON-ASB+PTFE ASB ASB+PTFE TEFLON NON ASBESTOS

Dimension

SIZE	L	ØA	ØB	W	H
2"	48	42	64	190	420
2-1/2"	51	57	80	190	430
3"	51	72	95	190	430
4"	51	95	120	220	520
5"	57	125	148	290	600
6"	57	150	175	290	660
8"	70	195	222	350	810
10"	70	250	275	350	990
12"	76	300	325	400	1150
14"	76	350	375	400	1230
16"	89	400	430	500	1420
18"	89	435	475	500	1600
20"	114	480	515	500	1700
24"	114	580	620	500	1970
28"	120	670	730	500	2300

Material List

NO.	PART NAME	MATERIAL
1	BODY	CF8.CF8M.CF3M
2	PLATE	SUS304. 316. 316L
3	STEM	SUS410. 304. 316. 316L
4	SEAT	TEFLON
5	GLAND	SUS304
6	GLAND PACKING	ASB NON-ASB
7	YOKE	DUCTILE IRON
8	YOKE SLEEVE	CAST BRONZE. FCD
9	BOLT NUT	SUS304
10	PAWLS	SUS304
11	HAND WHEEL	CAST IRON
12	NUT	CAST IRON