

**GBF-16 Cast Stainless Steel Globe Valve Flanged PN16
Outside Screw & Yoke Bolted Bonnet**

Feature

- Shell Wall Thickness: ANSI B16.34
- Face to Face DIN 3202
- End Flanges DIN 2501

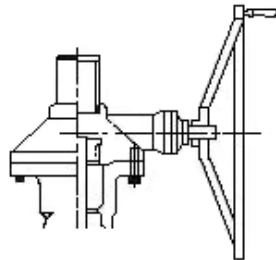

available with gear operator

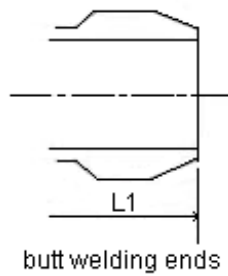
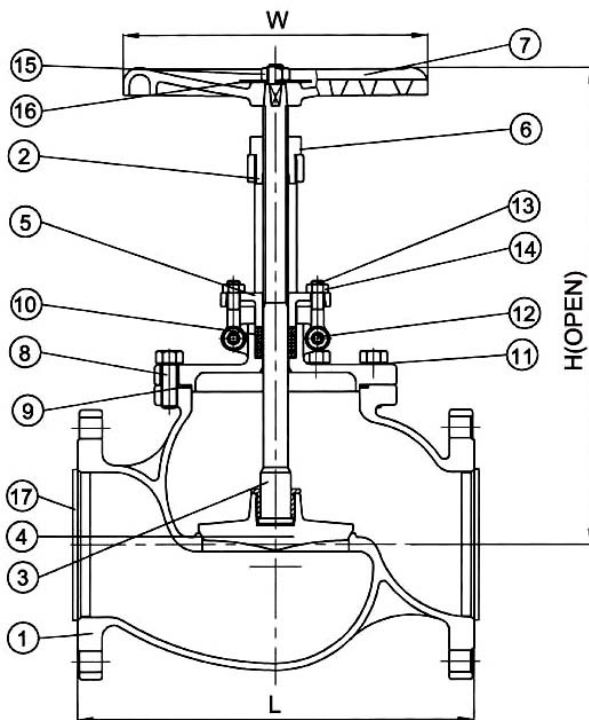

butt welding ends

Material List

NO.	PART NAME	MATERIAL		
		304SS	316SS	316L
1	BODY	1.4308	1.4408	1.4409
2	BONNET	1.4308	1.4408	1.4409
3	STEM	SUS304	SUS316	SUS316L
4	DISC SEAT	SUS304	SUS316	SUS316L
5	GRAND	1.4308	1.4408	1.4409
6	BUSH	BRONZE		
7	HAND WHEEL	DUCTILE IRON		
8	BONNET BOLT	A193-B8		
9	GASKET	SPIRAL WOUND/ GRAPHITE/PTFE		
10	PACKING	PTFE/GRAPHITE		
11	SPRING WASHER	A276-304		
12	EYE BOLT PIN	A276-304		
13	EYE BOLT	A194-B8		
14	EYE BOLT NUT	A194-8		
15	WHEEL NUT	A194-8		
16	WASHER	A276-304		
17	COVER	PE		

Test Pressure To API 598

	PN16
Shell Test (Water)	450 PSI (32 kg/cm ²)
Seat Test (Water)	314 PSI (22 kg/cm ²)
Seat Test (Air)	80PSI (6 kg/cm ²)

Dimension

SIZE	IN	1/2"	3/4"	1"	1-1/4"	1-1/2"	2"	2-1/2"	3"	4"	5"	6"	8"	10"	12"
	MM	15	20	25	32	40	50	65	80	100	125	150	200	250	300
L		130	150	160	180	200	230	290	310	350	400	480	500	600	700
H		190	200	230	270	280	320	390	415	510	600	710	900	1117	1324
W		90	90	100	140	140	160	180	200	225	250	290	330	350	400