

**GBF-1 Cast Stainless Steel Globe Valve Flanged 10K /150LB  
Outside Screw & Yoke Bolted Bonnet**

**Feature**

- Shell Wall Thickness: ANSI B16.34
- Face to Face ANSI B16.10 / JISB2002
- End Flanges ANSI B16.5 / JISB2210

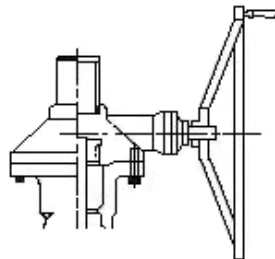

available with gear operator

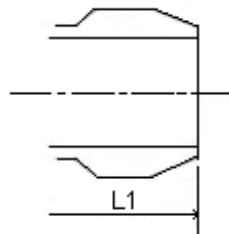

butt welding ends

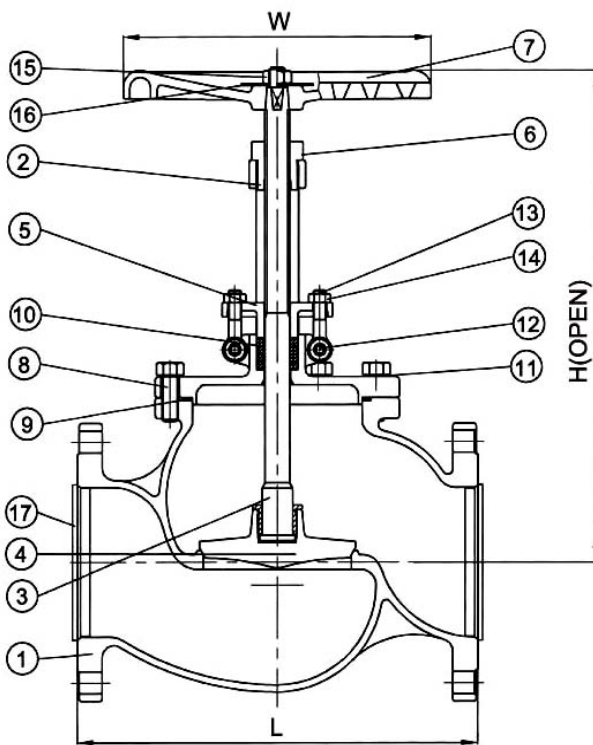

**Material List**

NO.	PART NAME	MATERIAL		
		304SS	316SS	316L
1	BODY	CF8	CF8M	CF3M
2	BONNET	CF8	CF8M	CF3M
3	STEM	SUS304	SUS316	SUS316L
4	DISC SEAT	SUS304	SUS316	SUS316L
5	GRAND	CF8	CF8M	CF3M
6	BUSH	BRONZE		
7	HAND WHEEL	DUCTILE IRON		
8	BONNET BOLT	A193-B8		
9	GASKET	SPIRAL WOUND/ GRAPHITE/PTFE		
10	PACKING	PTFE/GRAPHITE		
11	WASHER	A267-304		
12	EYE BOLT PIN	A276-304		
13	EYE BOLT	A194-B8		
14	EYE BOLT NUT	A194-8		
15	WHEEL NUT	A194-8		
16	WASHER	SUS304		
17	COVER	PE		

**Test Pressure To API 598**

	ANSI 150LB	JIS 10K
Shell Test (Water)	450 PSI (32 kg/cm <sup>2</sup> )	20 kg/cm <sup>2</sup>
Seat Test (Water)	314 PSI (22 kg/cm <sup>2</sup> )	15 kg/cm <sup>2</sup>
Seat Test (Air)	80 PSI (6 kg/cm <sup>2</sup> )	6 kg/cm <sup>2</sup>

**Dimension**

SIZE	IN	1/2"	3/4"	1"	1-1/2"	2"	2-1/2"	3"	4"	5"	6"	8"	10"	12"	14"	16"
	MM	15	20	25	40	50	65	80	100	125	150	200	250	300	350	400
L/L1		108	117	127	165	203	216	241	292	356	406	495	622	698	787	864
H		190	195	208	265	275	320	360	415	510	535	600	718	760	1050	1200
W		100	100	125	140	170	180	190	220	290	350	400	500	500	500	600