

**GTF-3 Cast Stainless Steel Gate Valve Flanged 20K/ 300LB
Outside Screw & Yoke Bolted Bonnet**

Feature

- Gate valves API 603
- Shell wall thickness ANSI B16.34
- Face to Face ANSI B16.10 / JISB2002
- End Flanges ANSI B16.5 / JISB2210

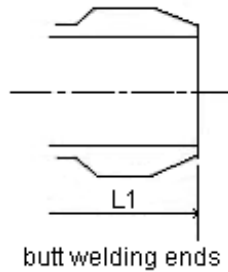
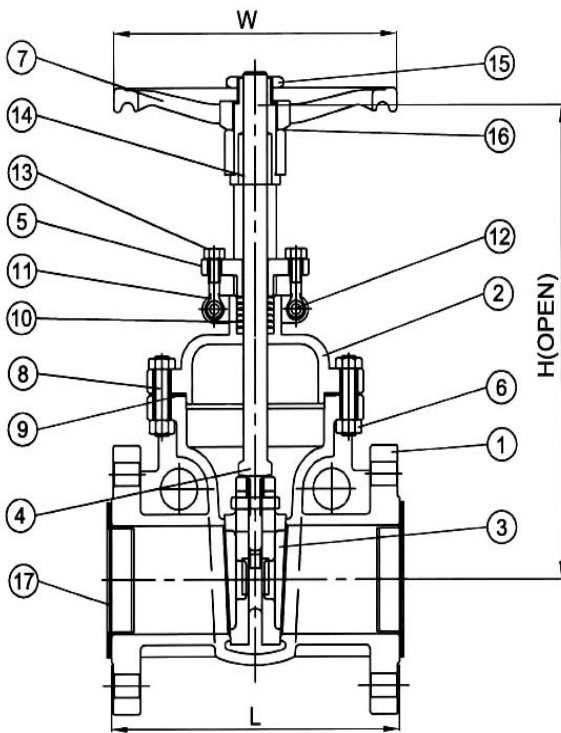
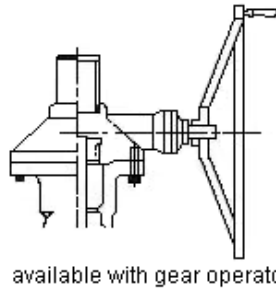

Material List

| NO. | PART NAME | MATERIAL | | | |
|-----|--------------|----------------------------|--------|---------|--------------|
| | | 304SS | 316SS | 316L | CARBON STEEL |
| 1 | BODY | CF8 | CF8M | CF3M | WCB |
| 2 | BONNET | CF8 | CF8M | CF3M | WCB |
| 3 | DISC | SUS304 | SUS316 | SUS316L | CF8 |
| 4 | STEM | SUS304 | SUS316 | SUS316L | SUS304 |
| 5 | GLAND | CF8 | CF8M | CF3M | CF8 |
| 6 | BONNET NUT | A194-8 | | | |
| 7 | HAND WHEEL | DUCTILE IRON | | | |
| 8 | BONNET BOLT | A193-B8 | | | |
| 9 | GASKET | SPIRALWOUND/ GRAPHITE/PTFE | | | |
| 10 | PACKING | PTFE/GRAPHITE | | | |
| 11 | EYE BOLT | A193-B8 | | | |
| 12 | EYE BOLT PIN | A276-304 | | | |
| 13 | EYE BOLT NUT | A194-8 | | | |
| 14 | YOKE SLEEVE | BRONZE | | | |
| 15 | WHEEL NUT | STEEL | | | |
| 16 | WASH | SUS304 | | | |
| 17 | COVER | PE | | | |

Test Pressure To API 598

| | ANSI 300LB | JIS 20k |
|--------------------|-----------------------------------|-----------------------|
| Shell Test (Water) | 1125 PSI (77 kg/cm ²) | 40 kg/cm ² |
| Seat Test (Water) | 814 PSI (56 kg/cm ²) | 20 kg/cm ² |
| Seat Test (Air) | 80 PSI (6 kg/cm ²) | 6 kg/cm ² |

Dimension

| SIZE | IN | 1/2" | 3/4" | 1" | 1-1/2" | 2" | 2-1/2" | 3" | 4" | 5" | 6" | 8" | 10" | 12" | 14" | 16" |
|------|----|------|------|-----|--------|-----|--------|-----|-----|-----|-----|------|------|------|------|------|
| | MM | 15 | 20 | 25 | 40 | 50 | 65 | 80 | 100 | 125 | 150 | 200 | 250 | 300 | 350 | 400 |
| L/L1 | | 140 | 152 | 165 | 190 | 216 | 241 | 283 | 305 | 381 | 403 | 419 | 459 | 502 | 762 | 838 |
| H | | 210 | 215 | 230 | 295 | 345 | 405 | 500 | 585 | 705 | 780 | 1000 | 1130 | 1410 | 1650 | 1750 |
| W | | 125 | 125 | 125 | 170 | 190 | 200 | 220 | 250 | 350 | 350 | 400 | 400 | 500 | 600 | 600 |