

3W4FD 3-Way Ball Valve Flanged 150LBS, Full Port, Direct Mount, L/ T/ X Port

Features

1. Flange ends conform to ANSI B16.5-1996
2. Investment casting
3. Blow-out proof stem
4. Pressure: 150LBS

Options

1. Carbon/ Stainless steel body construction
2. Locking device is available if requested



TURN PORT	TURN			
	0°	90°	180°	270°
L				
T				

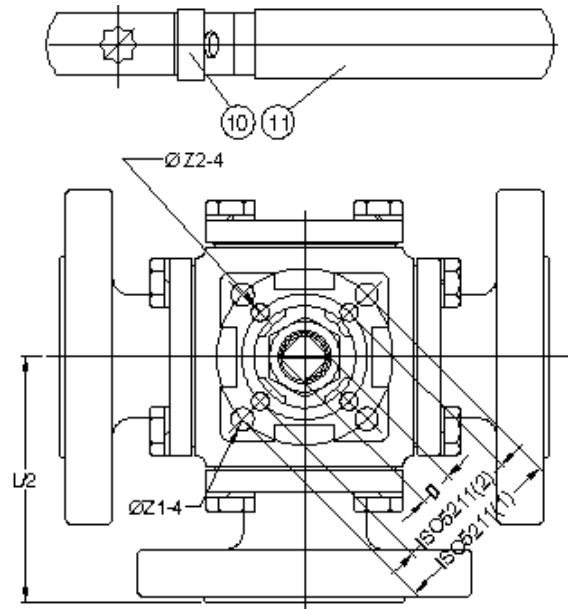
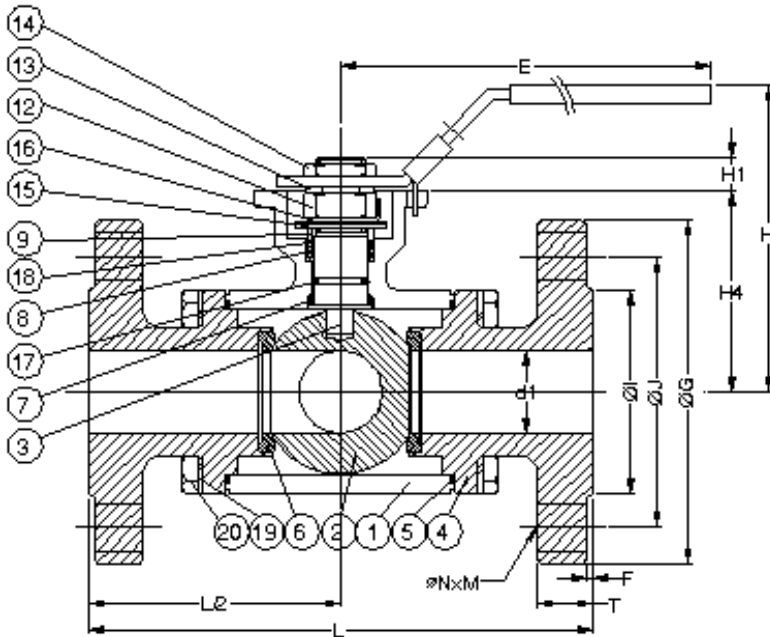

Material List

NO.	PART NAME	MATERIAL
1	BODY	SS316
2	BALL	SS316
3	STEM	SS316
4	END CAP	SS316
5	BODY SEAL	PTFE
6	SEAT	PTFE
7	THRUST WASHER	PTFE
8	STEM PACKING	PTFE
9	GLAND	SS304
10	HANDLE	SS304
11	HANDLE COVER	PLASTIC
12	STEM NUT	SS304
13	HANDLE WASHER	SS304
14	HANDLE NUT	SS304
15	BELLEVILLE WASHER	SS410
16	STOP WASHER	SS304
17	O-RING	VITON
18	PACKING FOLLOWER	PTFE + 25% GF
19	BOLT	SS304
20	BOLT WASHER	SS304

Dimension

SIZE	d1	L	E	H1	H	H4	C	G	J	I	T	F	M	N	Z1	Z2	ISO 5211
1/2"	16	147.2	186.5	9	89	47.8	9	89	60.5	35	11.1	1.6	4	16	6		42 F04
3/4"	20	153.5	218	11	98	58.2	9	98.6	70	43	11.1	1.6	4	16	7		50 F05
1"	25	169	218	11.5	102	64	9	108	79.2	51	11.1	1.6	4	16	7		50 F05
1 1/4"	32	192.5	235	15.2	118.5	79	14	117.5	88.9	63.5	12.7	1.6	4	16	9	7	50 F05 F07
1 1/2"	38	214.6	235	14.3	127	88.5	14	127	98.6	73.2	14.3	1.6	4	16	9	7	50 F05 F07
2"	50	221	260	17.8	149	105.8	17	152.5	120.7	92	15.9	1.6	4	16	11	9	70 F07 F10