

CKL Lift Type Check Valve Flanged 10K/ 150LB

Feature

- Shell Wall Thickness: ANSI B16.34
- Face to Face ANSI B16.10 / JISB2002
- End Flanges ANSI B16.5 / JISB2210
- Bolted cover
- Swing type
- For horizontal lines
- Renewable seat ring
- Flanged ends
- Buttwelding ends

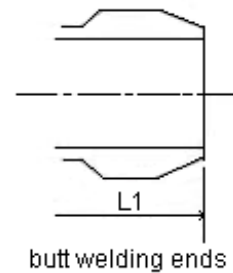
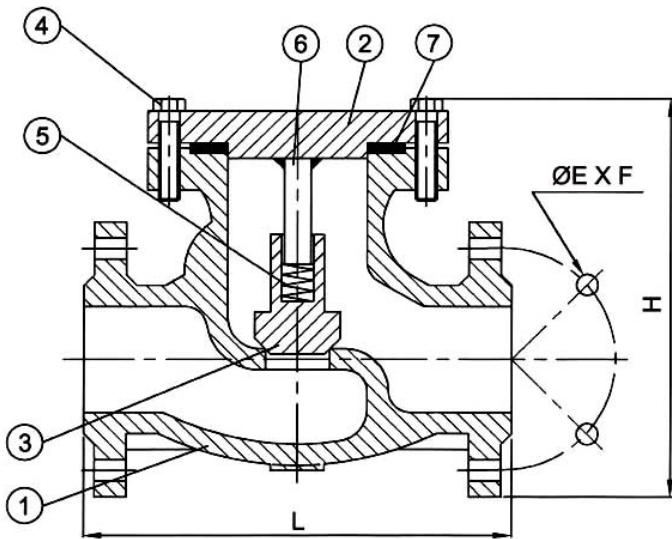

Test Pressure To API 598

	ANSI 150LB	JIS 10K
Shell Test (Water)	450 PSI (32 kg/cm ²)	20 kg/cm ²
Seat Test (Water)	314 PSI (22 kg/cm ²)	15 kg/cm ²
Seat Test (Air)	80PSI (6 kg/cm ²)	6 kg/cm ²

Material List

NO.	PART NAME	MATERIAL			
		WCB	304SS	316SS	316L
1	BODY	WCB	CF8	CF8M	CF3M
2	COVER	WCB	CF8	CF8M	CF3M
3	DISC	SUS304	CF8	CF8M	CF8M
4	BOLT	A193-B8			
5	SPRING	SUS304/SUS316			
6	STEM	A276-304/316/316L			
7	GASKET	V#1500/GRAPHITE/PTFE			

Dimension

SIZE	IN	1/2"	3/4"	1"	1-1/2"	2"	2-1/2"	3"	4"	5"	6"	8"	10"	12"	14"	16"
	MM	15	20	25	40	50	65	80	100	125	150	200	250	300	350	400
L		108	117	127	165	203	216	241	292	356	406	495	622	699	787	864
H		114	119	129	158	186	209	215	274	297	324	421	543	617	661	708