

3W3ML/ 3W3MT 3-Way Ball Valve 1000WOG, STD Port, Mounting Pad, L-Port/ T-Port

Features

1. Thread ends: NPT, BSPP, BSPF, BSPT, PT
2. Investment casting
3. Blow-out proof stem
4. Pressure: 1000WOG

Options

1. Carbon/ Stainless steel body construction
2. Locking device is available if requested

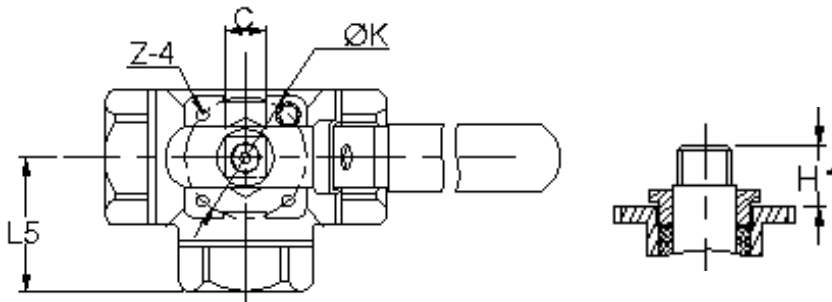

PORT \ TURN	0°	90°	180°	270°
	T			
L				

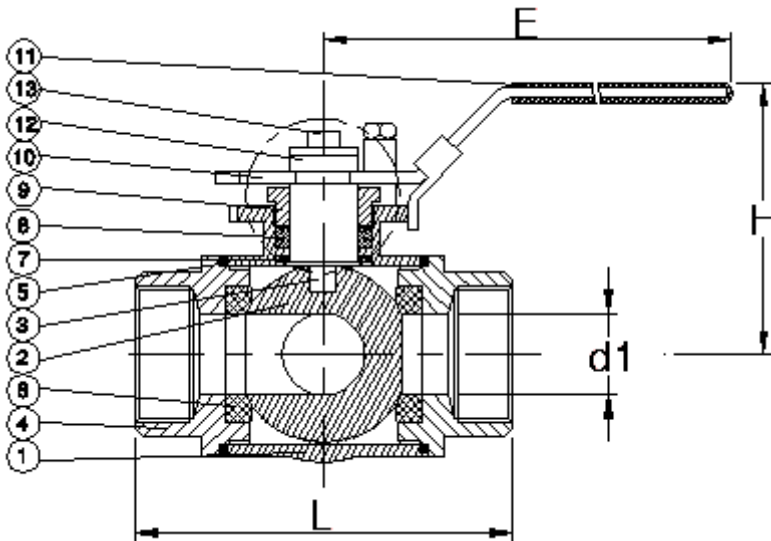

Material List

NO.	PART NAME	MATERIAL
1	BODY	SS316
2	BALL	SS316
3	STEM	SS316
4	END CAP	SS316
5	BODY SEAL	PTFE
6	SEAT	PTFE
7	THRUST WASHER	PTFE
8	STEM PACKING	PTFE
9	GLAND NUT	SS304
10	HANDLE	SS304
11	HANDLE COVER	PLASTIC
12	HANDLE WASHER	SS304
13	HANDLE NUT	SS304

Dimension

SIZE	d1	L	L5	E	H	H1	C	ØK	Z-4
DN8	1/4"	11.0	69.4	34.6	133.4	60.7	10.7	9.0	M5*P0.8
DN10	3/8"	11.0	69.4	34.6	133.4	60.7	10.7	9.0	M5*P0.8
DN15	1/2"	12.5	75.7	37.3	133.4	64.1	10.7	9.0	M5*P0.8
DN20	3/4"	16.0	86.6	44.7	178.5	82.4	13.9	11.0	M6*P1.0
DN25	1"	20.0	102.4	51.4	178.5	86.1	20.0	11.0	M6*P1.0
DN32	1-1/4"	25.0	118.2	57.7	209.9	91.4	23.8	11.0	M6*P1.0
DN40	1-1/2"	32.0	125.8	62.7	208.0	102.7	25.8	11.0	M8*P1.25
DN50	2"	38.0	149.0	74.6	229.9	110.7	25.3	14.0	M8*P1.25
DN65	2-1/2"	50.0	160.0	80.0	229.9	115.8	24.5	14.0	M8*P1.25
DN80	3"	65.0	185.0	92.5	265.0	132.0	25.5	17.0	M10*P1.5