

VBM3 3 Piece Ball Valve 1000WOG, Full Port



Features

- 1. Thread ends: NPT, BSPP, BSPF, BSPT, PT
Butt Weld: ASME B16.25
Socket Weld: ASME B16.11
- 2. Investment casting
- 3. Blow-out proof stem
- 4. Pressure: 1/4"~2" : 1000WOG
2-1/2"~4" : 800WOG

Options

- 1. Carbon/ Stainless steel body construction
- 2. Locking device is available if requested
- 3. Butt-welded end model : VBM3B
Socket-welded end model : VBM3S

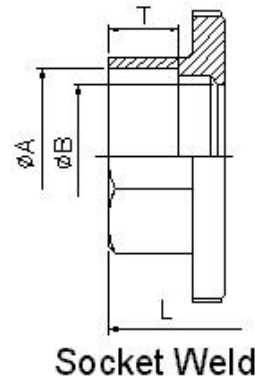
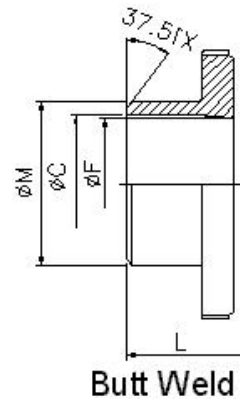
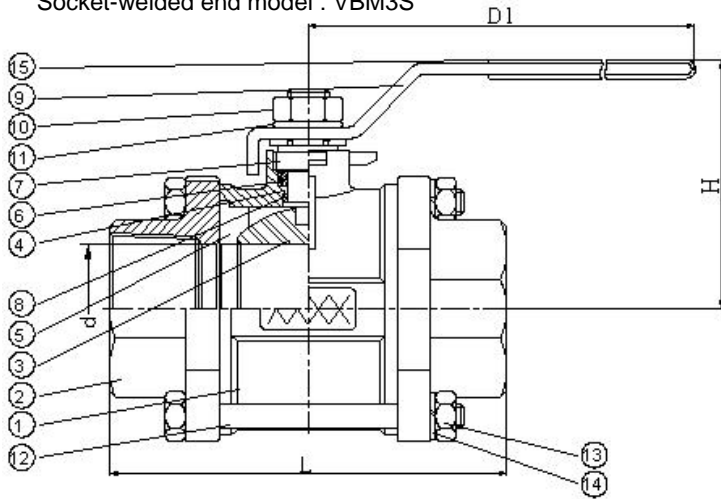

Material List

NO.	PART NAME	MATERIAL	
		STAINLESS STEEL	CARBON STEEL
1	BODY	ASTM A351 GR.CF8M	ASTM A216 WCB
2	CAP	ASTM A351 GR.CF8M	ASTM A216 WCB
3	BALL	ASTM A351 GR.CF8M	ASTM A351 GR.CF8M
4	STEM	ASTM A276 Gr.316	ASTM A276 Gr.316
5	BALL SEATS	PTFE	PTFE
6	STEM PACKING	PTFE	PTFE
7	GLAND	SS304	SS304
8	THRUST WASHER	PTFE	PTFE
9	HANDLE	SS304	SS304
10	HANDLE NUT	SS304	SS304
11	HANDLE WASHER	SS304	SS304
12	BOLTS	SS304	SS304
13	BOLTS BUTS	SS304	SS304
14	BOLTS WASHER	SS304	SS304
15	HANDLE SLEEVE	VINYL GRIP	VINYL GRIP

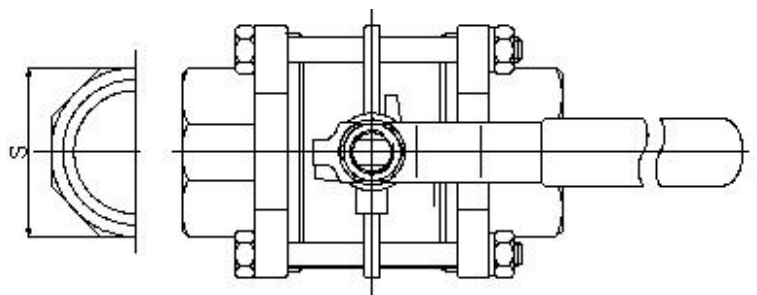

Dimension

SIZE	d	L	H	D1	S	A	B	T	C	F	M
1/4"	11.5	54.0	49.0	97.4	23.0	14.2	11.5	10	11	11	13.7
3/8"	12.5	54.0	49.0	97.4	23.0	17.5	12.5	10	12.5	12.5	17.1
1/2"	15.0	63.5	58	122.9	28.0	21.8	15	10	15.8	15	21.3
3/4"	20.0	72.5	61.0	122.9	34.0	27.4	20	13	20.9	20	26.7
1"	25.0	81.0	68	144.9	41.0	34.1	25	13	26.6	25	33.4
1-1/4"	32.0	94.5	73.5	144.9	50.0	42.7	32	13	35.1	32	42.2
1-1/2"	38.0	108	84.5	188.9	57.0	49	38.1	13	40.9	38.1	48.3
2"	50.0	121.5	93.2	188.9	69.0	61	50	16	52.5	50	60.3
2-1/2"	65.0	157.5	131.8	255.3	88.0	77	65	16	65	62.7	73
3"	80.0	190	140	260.8	102	90.2	80	16	77.9	77.9	88.9
4"	100	225	173.6	322.2	126	115.3	100	22	102.3	100	114.3