

DIN 2565 Threaded Flange With Neck PN6

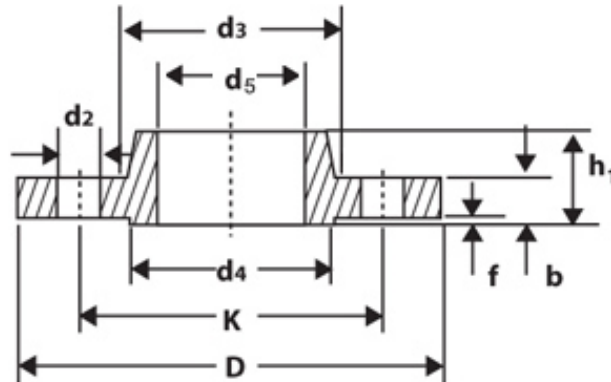

DN	D1	Thread DIN 2999	D	b	k	h	d3	d4	f	No. of holes	d2	KG
6	10.2	R1/8	65	10	40	18	18	25	2	4	11.5	0.19
8	13.5	R1/4	70	10	45	18	22	30	2	4	11.5	0.23
10	17.2	R3/8	75	12	50	20	25	35	2	4	11.5	0.32
15	21.3	R1/2	80	12	55	20	30	40	2	4	11.5	0.37
20	26.9	R3/4	90	14	65	24	40	50	2	4	11.5	0.58
25	33.7	R1	100	14	75	24	50	60	2	4	11.5	0.73
32	42.4	R1.1/4	120	14	90	26	60	70	2	4	14	1.05
40	48.3	R1.1/2	130	14	100	26	70	80	3	4	14	1.2
50	50.3	R2	140	14	110	28	80	90	3	4	14	1.54
65	76.1	R2.1/2	160	14	130	32	100	110	3	4	14	1.87
80	88.9	R3	190	16	150	34	110	128	3	4	18	2.78
100	114.3	R4	210	16	170	38	130	148	3	4	18	3.07
150	139.7	R5	240	18	200	40	160	178	3	8	18	4.33
200	168.3	R6	285	18	225	44	185	202	3	8	18	4.81

Dimensions in millimeter (mm).

DIN 2566 Threaded Flange With Neck PN16

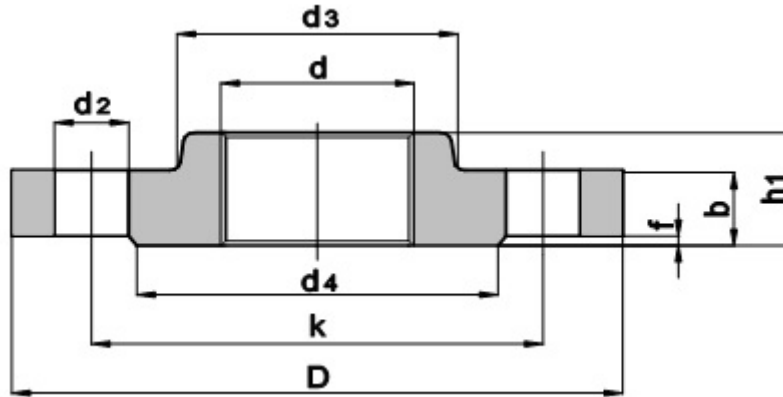

DN	d	Thread DIN 2999	D	b	k	h1	d3	d4	f	No. of holes	d2	KG
6	10.2	R1/8	75	12	50	18	20	32	2	4	11	0.33
8	13.5	R1/4	80	12	55	18	25	38	2	4	11	0.39
10	17.2	R3/8	90	14	60	20	30	40	2	4	14	0.56
15	21.3	R1/2	95	14	65	20	35	45	2	4	14	0.62
20	26.9	R3/4	105	16	75	24	45	58	2	4	14	0.92
25	33.7	R1	115	16	85	24	52	68	2	4	14	1.1
32	42.4	R1.1/4	140	16	100	26	60	78	2	4	18	1.59
40	48.3	R1.1/2	150	16	110	26	70	88	3	4	18	1.77
50	60.3	R2	165	18	125	28	85	102	3	4	18	2.41
65	76.1	R2.1/2	185	18	145	32	105	122	3	4	18	3.13
80	88.9	R3	200	20	160	34	118	138	3	4	18	3.95
100	114.3	R4	220	20	180	38	140	158	3	8	18	4.38
125	139.7	R3	250	22	210	40	168	188	3	8	18	5.99
150	168.3	R4	285	22	240	44	196	212	3	8	22	7.42

Dimensions in millimeter (mm).

DIN 2567 Threaded Flange With Neck PN25 and PN40

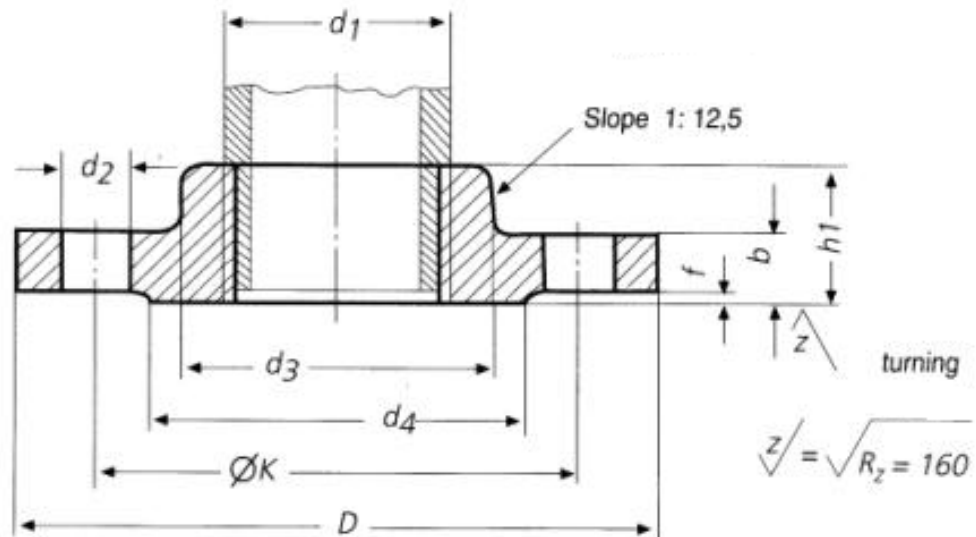

DN	d1	Thread DIN 2999	D	b	k	h1	d3	d4	f	No. of holes	Thread	d2	KG
6	10.2	R1/8	75	14	50	20	20	32	2	4	M10	11	0.388
8	13.5	R1/4	80	14	55	20	25	38	2	4	M10	11	0.450
10	17.2	R3/8	90	16	60	22	30	40	2	4	M12	14	0.630
15	21.3	R1/2	95	16	65	22	35	45	2	4	M12	14	0.710
20	26.9	R3/4	105	18	75	26	45	58	2	4	M12	14	1.030
25	33.7	R1	115	18	85	28	52	68	2	4	M12	14	1.280
32	42.4	R1.1/4	140	18	100	30	60	78	2	4	M16	18	1.870
40	48.3	R1.1/2	150	18	110	32	70	88	3	4	M16	18	2.140
50	60.3	R2	165	20	125	34	85	102	3	4	M16	18	2.850
65	76.1	R2.1/2	185	22	145	38	105	122	3	8	M16	18	3.850
80	88.9	R3	200	24	160	40	118	138	3	8	M16	18	4.800
100	114.3	R4	235	24	190	44	145	162	3	8	M20	22	6.430
125	139.7	R5	270	26	220	48	170	188	3	8	M24	26	8.770
150	165.1	R6	300	28	250	52	200	218	3	8	M24	26	10.500

Dimensions in millimeter (mm).

DIN 2568 Threaded Flange With Neck PN64

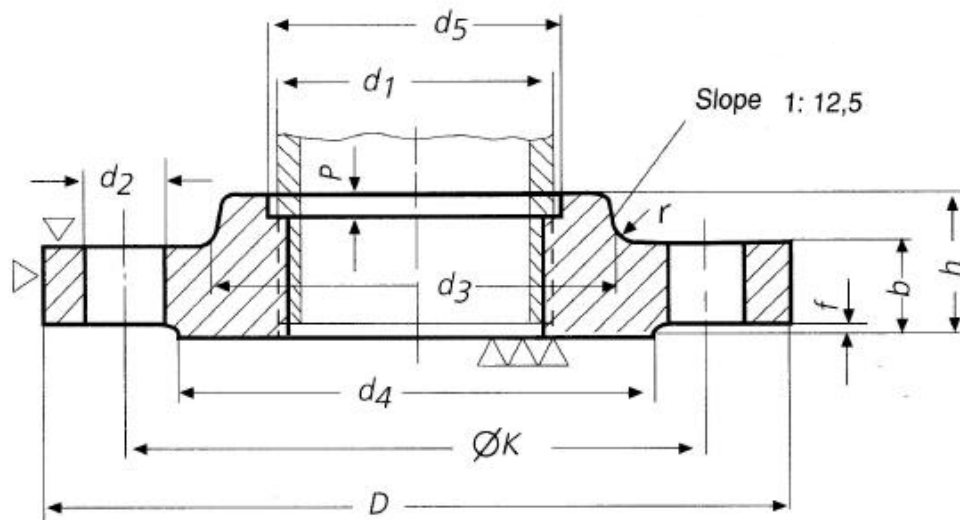

DN	d1	Thread DIN 2999	D	b	k	h1	d3	d5	P	r	d4	f	No. of holes	Thread	d2	KG
10 to 40	See DIN 2569															
50	60.3	R2	180	26	135	36	90	61	7	3	108	3	4	M20	22	4.29
65	76.1	R2.1/2	205	26	160	40	112	77	7	3	132	3	8	M20	22	5.48
80	88.9	R3	215	28	170	44	125	90	7	3	142	3	8	M20	22	6.42
100	114	R4	250	30	200	52	152	116	7	3	170	3	8	M24	26	9.25
125	140	R5	295	34	240	56	185	141	7	3	205	3	8	M27	30	14.4
150	165	R6	345	36	280	60	215	167	7	3	240	3	8	M30	33	20.7

Dimensions in millimeter (mm).

DIN 2569 Threaded Flange With Neck PN100

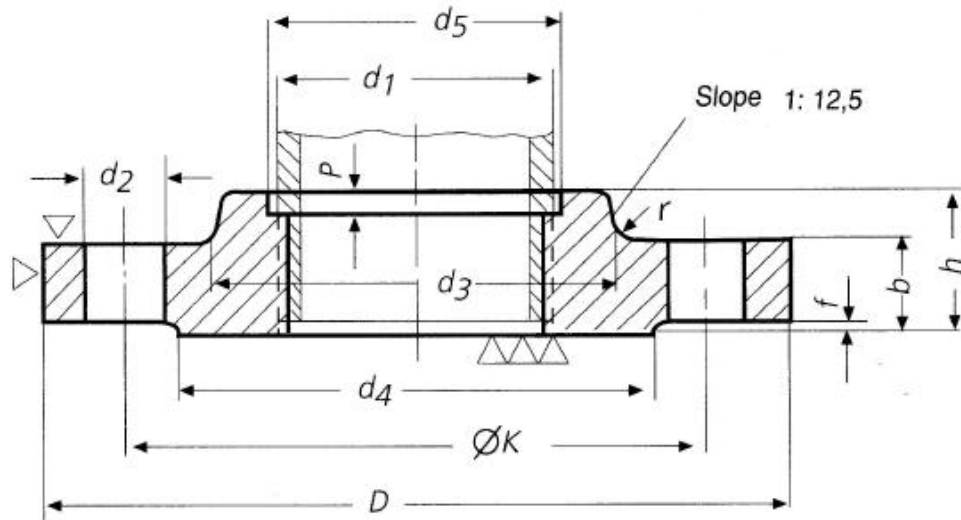

DN	d1	Thread DIN 2999	D	b	k	h1	d3	d5	P	r	d4	f	No. of holes	Thread	d2	KG
10	17.2	R3/8	100	20	70	28	40	18	4	2	50	2	4	M12	14	1.08
15	21.3	R1/2	105	20	75	28	43	22	6	2	55	2	4	M12	14	1.19
20	26.9	R3/4	130	22	90	30	52	28	7	2	68	2	4	M16	18	2.00
25	33.7	R1	140	24	100	32	60	35	7	3	78	2	4	M16	18	2.54
32	42.4	R1.1/4	155	24	110	32	68	43	7	3	85	2	4	M20	22	2.99
40	48.3	R1.1/2	170	26	125	34	80	49	7	3	98	3	4	M20	22	3.87
50	60.3	R2	195	28	145	36	95	61	7	3	115	3	4	M24	26	5.42
65	76.1	R2.1/2	220	30	170	40	118	77	7	3	140	3	8	M24	26	7.11
80	88.9	R3	230	32	180	44	130	90	7	3	150	3	8	M24	26	8.21
100	114	R4	265	36	210	52	158	116	7	3	175	3	8	M27	30	12.1
125	140	R5	315	40	250	56	188	141	7	3	210	3	8	M30	33	18.6
150	165	R6	355	44	290	60	225	167	7	3	250	3	12	M30	33	25.1

Dimensions in millimeter (mm).