

Street Elbow Threaded

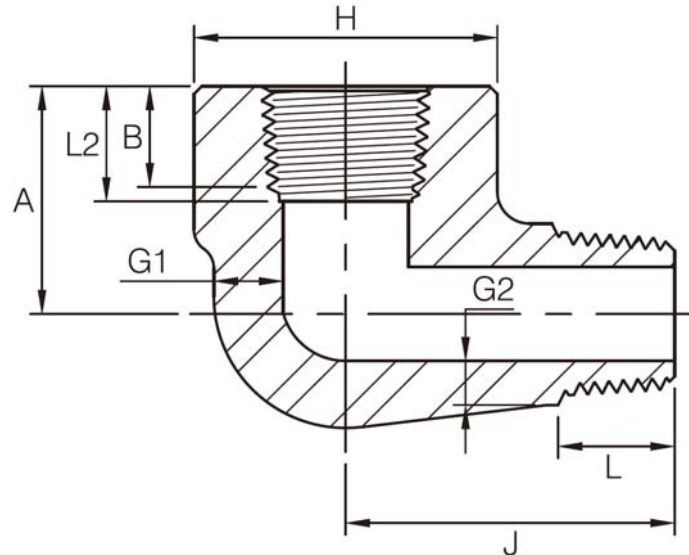

DN	Nom. Pipe Size	H		A		J		G1 (Min)		G2 ⁽¹⁾ (Min)		B ⁽²⁾ (Min)	L2 ⁽²⁾ (Min)	L (Min)
		3M	6M	3M	6M	3M	6M	3M	6M	3M	6M			
6	1/8"	19	25	19	22	25	32	3.18	5.08	2.74	4.22	6.4	6.7	10.0
8	1/4"	25	32	22	25	32	38	3.30	5.66	3.22	5.28	8.1	10.2	11.0
10	3/8"	32	38	25	28	38	41	3.50	6.98	3.50	5.59	9.1	10.4	13.0
15	1/2"	38	44	28	35	41	48	4.09	8.15	4.16	6.53	10.9	13.6	14.0
20	3/4"	44	51	35	44	48	57	4.32	8.53	4.88	6.86	12.7	13.9	16.0
25	1"	51	62	44	51	57	66	4.98	9.93	5.56	7.95	14.7	17.3	19.0
32	1-1/4"	62	70	51	54	66	71	5.28	10.59	5.56	8.48	17.0	18.0	21.0
40	1-1/2"	70	84	54	64	71	84	5.56	11.07	6.25	8.89	17.8	18.4	21.0
50	2"	84	102	64	83	84	105	7.14	12.09	7.64	9.70	19.0	19.0	22.0

- (1) Wall thickness before threading.
- (2) Dimension B is minimum length of perfect thread. The length of useful thread (B plus threads with fully formed roots and flat crests) shall not be less than L2 (effective length of external thread) required by American National Standard for pipe threads (ANSI / ASME B1.20.1).
- (3) 3M and 6M denote 3000Lb and 6000Lb.
- (4) Dimensions in accordance with ASME B16.11-2011.