

Couplet Threaded

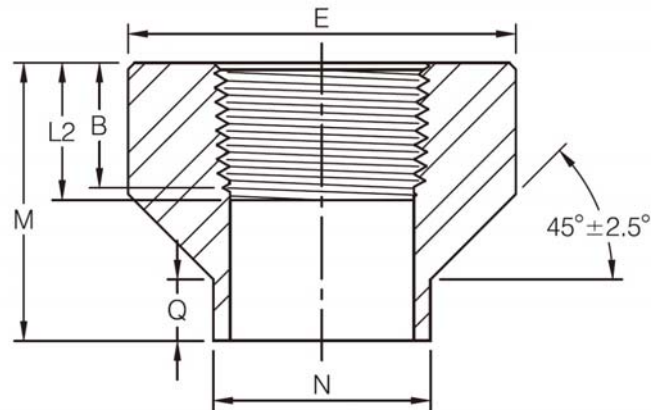

DN	Nom. Pipe Size	N	Q	M	E		Length of Thread (Min)	
					3000Lb	6000Lb	B ⁽¹⁾	L2 ⁽¹⁾
8	1/4"	17.5	9.5	30.2	23.8	25.4	8.1	10.2
10	3/8"	20.7	9.5	30.2	27.0	31.8	9.1	10.4
15	1/2"	23.8	9.5	33.4	33.4	38.1	10.9	13.6
20	3/4"	27.0	9.5	34.9	38.1	44.5	12.7	13.9
25	1"	33.4	9.5	42.9	46.1	57.2	14.7	17.3
32	1-1/4"	42.9	9.5	47.6	55.6	63.5	17.0	18.0
40	1-1/2"	49.2	9.5	50.8	63.5	76.2	17.8	18.4
50	2"	61.9	9.5	57.2	79.4	92.1	19.0	19.2
65	2-1/2"	73.0	9.5	63.5	92.1	108.0	23.6	28.9
80	3"	88.9	9.5	69.9	111.1	127.0	25.9	30.5
100	4"	114.3	9.5	76.2	141.3	158.8	27.7	33.0

- (1) Dimension B is minimum length of perfect thread. The length of useful thread (B plus threads with fully formed roots and flat crests) shall not be less than L2 (effective length of external thread) required by American National Standard for pipe threads (ANSI / ASME B1.20.1).
- (2) Dimensions in accordance with ASME B16.11-2011.