

Concentric Swage Nipple

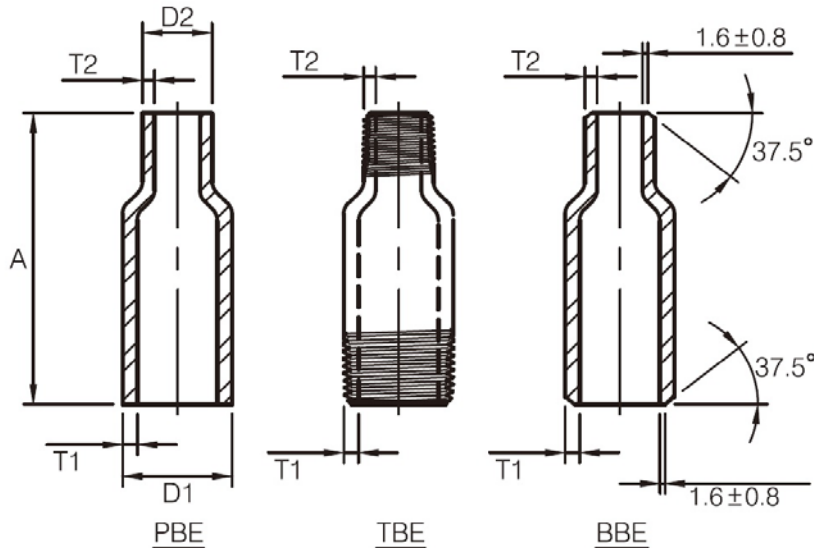

Nom. Pipe Size	Outside Diameter		Wall Thickness								
	Large End D1	Small End D2	T1					T2			
			End To End "A"	Sch40 (STD)	Sch80 (XS)	Sch160	XXS	Sch40 (STD)	Sch80 (XS)	Sch160	XXS
1/4"x1/8"	13.7	10.3	57	2.2	3.0	3.7	6.1	1.7	2.4	-	-
3/8"x1/8"	17.1	10.3	64	2.3	3.2	4.0	6.4	1.7	2.4	-	-
3/8"x1/4"	17.1	13.7	64	2.3	3.2	4.0	6.4	2.2	3.0	-	-
1/2"x1/8"	21.3	10.3	70	2.8	3.7	4.8	7.5	1.7	2.4	-	-
1/2"x1/4"	21.3	13.7	70	2.8	3.7	4.8	7.5	2.2	3.0	-	-
1/2"x3/8"	21.3	17.1	70	2.8	3.7	4.8	7.5	2.3	3.2	-	-
3/4"x1/8"	26.7	10.3	76	2.9	3.9	5.6	7.8	1.7	2.4	-	-
3/4"x1/4"	26.7	13.7	76	2.9	3.9	5.6	7.8	2.2	3.0	-	-
3/4"x3/8"	26.7	17.1	76	2.9	3.9	5.6	7.8	2.3	3.2	-	-
3/4"x1/2"	26.7	21.3	76	2.9	3.9	5.6	7.8	2.8	3.7	4.8	7.5
1"x1/8"	33.4	10.3	89	3.4	4.5	6.4	9.1	1.7	2.4	-	-
1"x1/4"	33.4	13.7	89	3.4	4.5	6.4	9.1	2.2	3.0	-	-
1"x3/8"	33.4	17.1	89	3.4	4.5	6.4	9.1	2.3	3.2	-	-
1"x1/2"	33.4	21.3	89	3.4	4.5	6.4	9.1	2.8	3.7	4.8	7.5
1"x3/4"	33.4	26.7	89	3.4	4.5	6.4	9.1	2.9	3.9	5.6	7.8
1-1/4"x1/8"	42.2	10.3	102	3.6	4.9	6.4	9.7	1.7	2.4	-	-
1-1/4"x1/4"	42.2	13.7	102	3.6	4.9	6.4	9.7	2.2	3.0	-	-
1-1/4"x3/8"	42.2	17.1	102	3.6	4.9	6.4	9.7	2.3	3.2	-	-
1-1/4"x1/2"	42.2	21.3	102	3.6	4.9	6.4	9.7	2.8	3.7	4.8	7.5
1-1/4"x3/4"	42.2	26.7	102	3.6	4.9	6.4	9.7	2.9	3.9	5.6	7.8
1-1/4"x1"	42.2	33.4	102	3.6	4.9	6.4	9.7	3.4	4.5	6.4	9.1
1-1/2"x1/8"	48.3	10.3	114	3.7	5.1	7.1	10.2	1.7	2.4	-	-
1-1/2"x1/4"	48.3	13.7	114	3.7	5.1	7.1	10.2	2.2	3.0	-	-
1-1/2"x3/8"	48.3	17.1	114	3.7	5.1	7.1	10.2	2.3	3.2	-	-
1-1/2"x1/2"	48.3	21.3	114	3.7	5.1	7.1	10.2	2.8	3.7	4.8	7.5
1-1/2"x3/4"	48.3	26.7	114	3.7	5.1	7.1	10.2	2.9	3.9	5.6	7.8
1-1/2"x1"	48.3	33.4	114	3.7	5.1	7.1	10.2	3.4	4.5	6.4	9.1
1-1/2"x1-1/4"	48.3	42.2	114	3.7	5.1	7.1	10.2	3.6	4.9	6.4	9.7
2"x1/8"	60.3	10.3	165	3.9	5.5	8.7	11.1	1.7	2.4	-	-
2"x1/4"	60.3	13.7	165	3.9	5.5	8.7	11.1	2.2	3.0	-	-
2"x3/8"	60.3	17.1	165	3.9	5.5	8.7	11.1	2.3	3.2	-	-
2"x1/2"	60.3	21.3	165	3.9	5.5	8.7	11.1	2.8	3.7	4.8	7.5
2"x3/4"	60.3	26.7	165	3.9	5.5	8.7	11.1	2.9	3.9	5.6	7.8

Concentric Swage Nipple

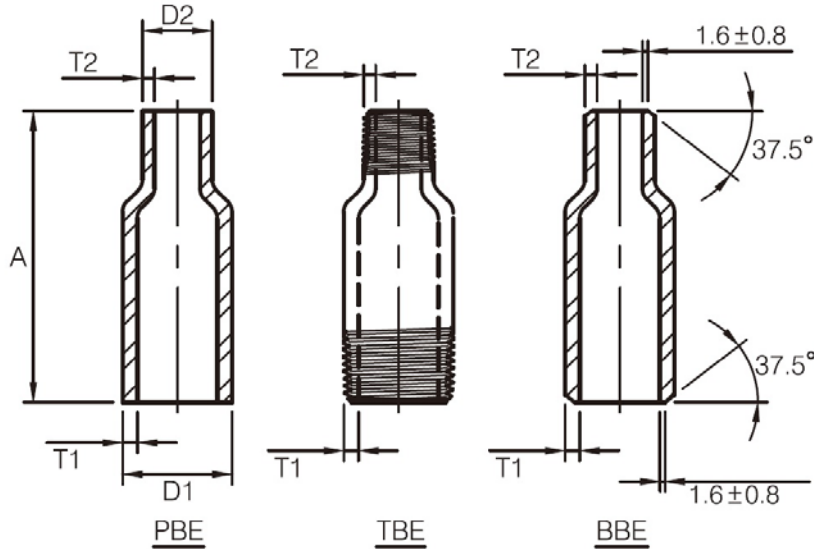

Nom. Pipe Size	Outside Diameter		Wall Thickness									
	Large End D1	Small End D2	T1				T2					
			End To End "A"	Sch40 (STD)	Sch80 (XS)	Sch160	XXS	Sch40 (STD)	Sch80 (XS)	Sch160	XXS	
2"x1"	60.3	33.4	165	3.9	5.5	8.7	11.1	3.4	4.5	6.4	9.1	
2"x1-1/4"	60.3	42.2	165	3.9	5.5	8.7	11.1	3.6	4.9	6.4	9.7	
2"x1-1/2"	60.3	48.3	165	3.9	5.5	8.7	11.1	3.7	5.1	7.1	10.2	
2-1/2"x1/8"	73.0	10.3	178	5.2	7.0	9.5	14.0	1.7	2.4	-	-	
2-1/2"x1/4"	73.0	13.7	178	5.2	7.0	9.5	14.0	2.2	3.0	-	-	
2-1/2"x3/8"	73.0	17.1	178	5.2	7.0	9.5	14.0	2.3	3.2	-	-	
2-1/2"x1/2"	73.0	21.3	178	5.2	7.0	9.5	14.0	2.8	3.7	4.8	7.5	
2-1/2"x3/4"	73.0	26.7	178	5.2	7.0	9.5	14.0	2.9	3.9	5.6	7.8	
2-1/2"x1"	73.0	33.4	178	5.2	7.0	9.5	14.0	3.4	4.5	6.4	9.1	
2-1/2"x1-1/4"	73.0	42.2	178	5.2	7.0	9.5	14.0	3.6	4.9	6.4	9.7	
2-1/2"x1-1/2"	73.0	48.3	178	5.2	7.0	9.5	14.0	3.7	5.1	7.1	10.2	
2-1/2"x2"	73.0	60.3	178	5.2	7.0	9.5	14.0	3.9	5.5	8.7	11.1	
3"x1/8"	88.9	10.3	203	5.5	7.6	11.1	15.2	1.7	2.4	-	-	
3"x1/4"	88.9	13.7	203	5.5	7.6	11.1	15.2	2.2	3.0	-	-	
3"x3/8"	88.9	17.1	203	5.5	7.6	11.1	15.2	2.3	3.2	-	-	
3"x1/2"	88.9	21.3	203	5.5	7.6	11.1	15.2	2.8	3.7	4.8	7.5	
3"x3/4"	88.9	26.7	203	5.5	7.6	11.1	15.2	2.9	3.9	5.6	7.8	
3"x1"	88.9	33.4	203	5.5	7.6	11.1	15.2	3.4	4.5	6.4	9.1	
3"x1-1/4"	88.9	42.2	203	5.5	7.6	11.1	15.2	3.6	4.9	6.4	9.7	
3"x1-1/2"	88.9	48.3	203	5.5	7.6	11.1	15.2	3.7	5.1	7.1	10.2	
3"x2"	88.9	60.3	203	5.5	7.6	11.1	15.2	3.9	5.5	8.7	11.1	
3"x2-1/2"	88.9	73.0	203	5.5	7.6	11.1	15.2	5.2	7.0	9.5	14.0	
3-1/2"x1/8"	101.6	10.3	203	5.7	8.1	-	-	1.7	2.4	-	-	
3-1/2"x1/4"	101.6	13.7	203	5.7	8.1	-	-	2.2	3.0	-	-	
3-1/2"x3/8"	101.6	17.1	203	5.7	8.1	-	-	2.3	3.2	-	-	
3-1/2"x1/2"	101.6	21.3	203	5.7	8.1	-	-	2.8	3.7	4.8	7.5	
3-1/2"x3/4"	101.6	26.7	203	5.7	8.1	-	-	2.9	3.9	5.6	7.8	
3-1/2"x1"	101.6	33.4	203	5.7	8.1	-	-	3.4	4.5	6.4	9.1	
3-1/2"x1-1/4"	101.6	42.2	203	5.7	8.1	-	-	3.6	4.9	6.4	9.7	
3-1/2"x1-1/2"	101.6	48.3	203	5.7	8.1	-	-	3.7	5.1	7.1	10.2	
3-1/2"x2"	101.6	60.3	203	5.7	8.1	-	-	3.9	5.5	8.7	11.1	
3-1/2"x2-1/2"	101.6	73.0	203	5.7	8.1	-	-	5.2	7.0	9.5	14.0	
3-1/2"x3"	101.6	88.9	203	5.7	8.1	-	-	5.5	7.6	11.1	15.2	

Concentric Swage Nipple

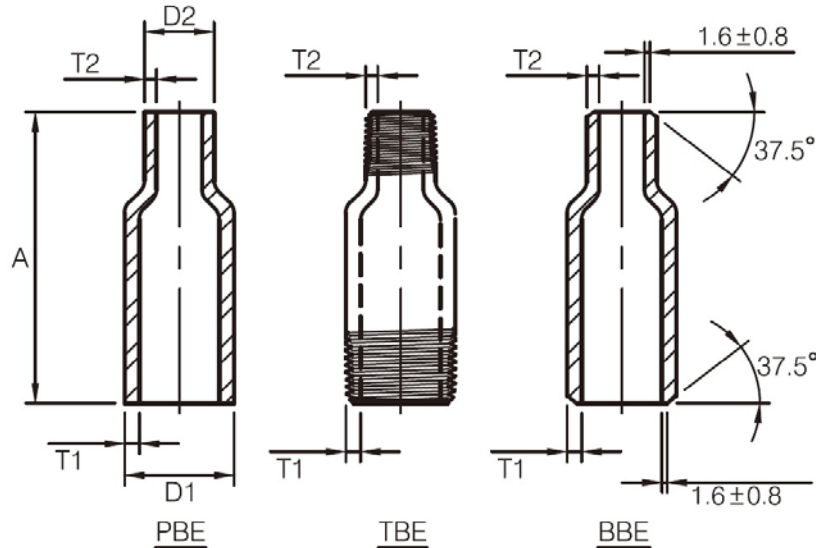

Nom. Pipe Size	Outside Diameter		Wall Thickness								
	Large End D1	Small End D2	T1					T2			
			End To End "A"	Sch40 (STD)	Sch80 (XS)	Sch160	XXS	Sch40 (STD)	Sch80 (XS)	Sch160	XXS
4"x1/4"	114.3	13.7	229	6.0	8.6	13.5	17.1	2.2	3.0	-	-
4"x3/8"	114.3	17.1	229	6.0	8.6	13.5	17.1	2.3	3.2	-	-
4"x1/2"	114.3	21.3	229	6.0	8.6	13.5	17.1	2.8	3.7	4.8	7.5
4"x3/4"	114.3	26.7	229	6.0	8.6	13.5	17.1	2.9	3.9	5.6	7.8
4"x1"	114.3	33.4	229	6.0	8.6	13.5	17.1	3.4	4.5	6.4	9.1
4"x1-1/4"	114.3	42.2	229	6.0	8.6	13.5	17.1	3.6	4.9	6.4	9.7
4"x1-1/2"	114.3	48.3	229	6.0	8.6	13.5	17.1	3.7	5.1	7.1	10.2
4"x2"	114.3	60.3	229	6.0	8.6	13.5	17.1	3.9	5.5	8.7	11.1
4"x2-1/2"	114.3	73.0	229	6.0	8.6	13.5	17.1	5.2	7.0	9.5	14.0
4"x3"	114.3	88.9	229	6.0	8.6	13.5	17.1	5.5	7.6	11.1	15.2
4"x3-1/2"	114.3	101.6	229	6.0	8.6	13.5	17.1	5.7	8.1	-	-

(1) Dimensions in accordance with MSS SP-95-2014.

(2) Wall Thickness (T1 & T2) in accordance with ASME B36.10M.

(3) Connection end types:

PBE : Plain Both Ends

PSE : Plain Small End

PLE : Plain Large End

BBE : Bevel Both Ends

BSE : Bevel Small End

BLE : Bevel Large End

TBE : Thread Both Ends

TSE : Thread Small End

TLE : Thread Large End