

45° Elbow Threaded

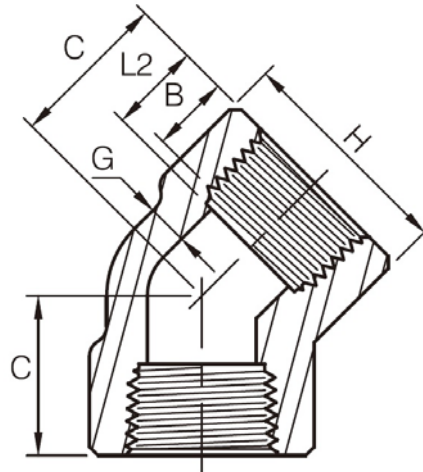

DN	Nom. Pipe Size	Center to End C			Outside Diameter Of Band H			Minimum Wall Thickness G			Length of Thread (Min)	
		2M	3M	6M	2M	3M	6M	2M	3M	6M	B ⁽¹⁾	L2 ⁽¹⁾
6	1/8"	17	17	19	22	22	25	3.18	3.18	6.35	6.4	6.7
8	1/4"	17	19	22	22	25	33	3.18	3.30	6.60	8.1	10.2
10	3/8"	19	22	25	25	33	38	3.18	3.51	6.98	9.1	10.4
15	1/2"	22	25	28	33	38	46	3.18	4.09	8.15	10.9	13.6
20	3/4"	25	28	33	38	46	56	3.18	4.32	8.53	12.7	13.9
25	1"	28	33	35	46	56	62	3.68	4.98	9.93	14.7	17.3
32	1-1/4"	33	35	43	56	62	75	3.89	5.28	10.59	17.0	18.0
40	1-1/2"	35	43	44	62	75	84	4.01	5.56	11.07	17.8	18.4
50	2"	43	44	52	75	84	102	4.27	7.14	12.09	19.0	19.2
65	2-1/2"	52	52	64	92	102	121	5.61	7.65	15.29	23.6	28.9
80	3"	64	64	79	109	121	146	5.99	8.84	16.64	25.9	30.5
100	4"	79	79	79	146	152	152	6.55	11.18	18.67	27.7	33.0

(1) Dimension B is minimum length of perfect thread. The length of useful thread (B plus threads with fully formed roots and flat crests) shall not be less than L2 (effective length of external thread) required by American National Standard for pipe threads (ANSI / ASME B1.20.1).

(2) 2M, 3M and 6M denote 2000Lb, 3000Lb and 6000Lb.

(3) Dimensions in accordance with ASME B16.11-2011.