

Nipple Branch Outlet Butt Weld (Bevel / Plain End)

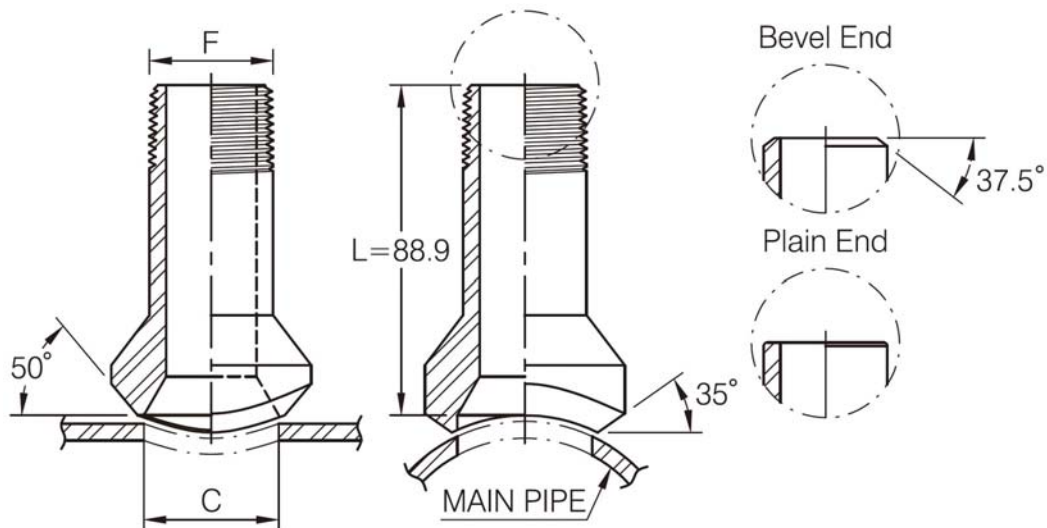

Outlet Pipe	C		F
	3000LB - XS	6000LB - S160	
1/2"	23.8	13.8	21.3
3/4"	30.2	18.9	26.7
1"	36.5	24.3	33.4
1-1/4"	44.5	32.5	42.2
1-1/2"	50.8	38.1	48.3
2"	65.1	49.2	60.3

- (1) Range: Sch40, STD, Sch80, XS, Sch160, XXS.
- (2) Weld bevel in accordance with ASME B16.25.