

Half Coupling Socket Weld

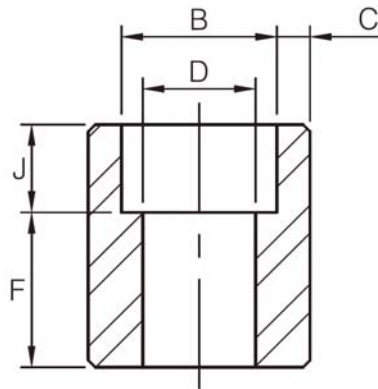

DN	Nom. Pipe Size	Socket Bore Dia. B	Bore Dia. Of Fitting D			Socket Wall Thickness C ⁽¹⁾						Laying Length F	Depth of Socket (Min) J
						3M		6M		9M			
			3M	6M	9M	Avg	Min	Avg	Min	Avg	Min		
6	1/8"	10.8	6.9	4.0	-	3.18	3.18	3.96	3.43	-	-	16.0	9.5
8	1/4"	14.2	9.3	6.4	-	3.78	3.30	4.60	4.01	-	-	16.0	9.5
10	3/8"	17.6	12.6	9.2	-	4.01	3.50	5.03	4.37	-	-	17.5	9.5
15	1/2"	21.8	15.8	11.8	6.4	4.67	4.09	5.97	5.18	9.35	8.18	22.5	9.5
20	3/4"	27.2	21.0	15.6	11.1	4.90	4.27	6.96	6.04	9.78	8.56	24.0	12.5
25	1"	33.9	26.7	20.7	15.2	5.69	4.98	7.92	6.93	11.38	9.96	28.5	12.5
32	1-1/4"	42.7	35.1	29.5	22.8	6.07	5.28	7.92	6.93	12.14	10.62	30.0	12.5
40	1-1/2"	48.8	40.9	34.0	28.0	6.35	5.54	8.92	7.80	12.70	11.12	32.0	12.5
50	2"	61.2	52.5	42.9	38.2	6.93	6.04	10.92	9.50	13.84	12.12	41.0	16.0
65	2-1/2"	73.9	62.7	-	-	8.76	7.67	-	-	-	-	43.0	16.0
80	3"	89.8	78.0	-	-	9.52	8.30	-	-	-	-	44.5	16.0
100	4"	115.2	102.3	-	-	10.69	9.35	-	-	-	-	48.0	19.0

- (1) Average of socket wall thickness around periphery shall be no less than listed values. The minimum values are permitted in localized areas.
- (2) 3M, 6M and 9M denote 3000Lb, 6000Lb and 9000Lb.
- (3) Reducer: "C, J, E" in accordance with large size, "D" in accordance with small size and the others in accordance with each size.
- (4) Dimensions in accordance with ASME B16.11-2011.