

# FORGED PIPE FITTINGS

WELLGROW INDUSTRIES CORP.



- ▲ **Threaded Fittings**
- ▲ **Socket Weld Fittings**

## 90° Elbow Threaded

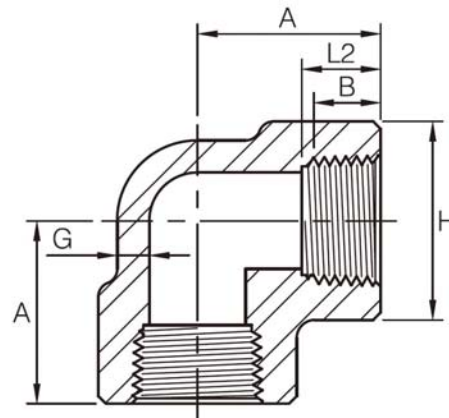

DN	Nom. Pipe Size	Center to End A			Outside Diameter Of Band H			Minimum Wall Thickness G			Length of Thread (Min)	
		2M	3M	6M	2M	3M	6M	2M	3M	6M	B <sup>(1)</sup>	L2 <sup>(1)</sup>
6	1/8"	21	21	25	22	22	25	3.18	3.18	6.35	6.4	6.7
8	1/4"	21	25	28	22	25	33	3.18	3.30	6.60	8.1	10.2
10	3/8"	25	28	33	25	33	38	3.18	3.51	6.98	9.1	10.4
15	1/2"	28	33	38	33	38	46	3.18	4.09	8.15	10.9	13.6
20	3/4"	33	38	44	38	46	56	3.18	4.32	8.53	12.7	13.9
25	1"	38	44	51	46	56	62	3.68	4.98	9.93	14.7	17.3
32	1-1/4"	44	51	60	56	62	75	3.89	5.28	10.59	17.0	18.0
40	1-1/2"	51	60	64	62	75	84	4.01	5.56	11.07	17.8	18.4
50	2"	60	64	83	75	84	102	4.27	7.14	12.09	19.0	19.2
65	2-1/2"	76	83	95	92	102	121	5.61	7.65	15.29	23.6	28.9
80	3"	86	95	106	109	121	146	5.99	8.84	16.64	25.9	30.5
100	4"	106	114	114	146	152	152	6.55	11.18	18.67	27.7	33.0

- (1) Dimension B is minimum length of perfect thread. The length of useful thread (B plus threads with fully formed roots and flat crests) shall not be less than L2 (effective length of external thread) required by American National Standard for pipe threads (ANSI / ASME B1.20.1).
- (2) 2M, 3M and 6M denote 2000Lb, 3000Lb and 6000Lb.
- (3) Dimension in accordance with ASME B16.11-2011.

## 45° Elbow Threaded

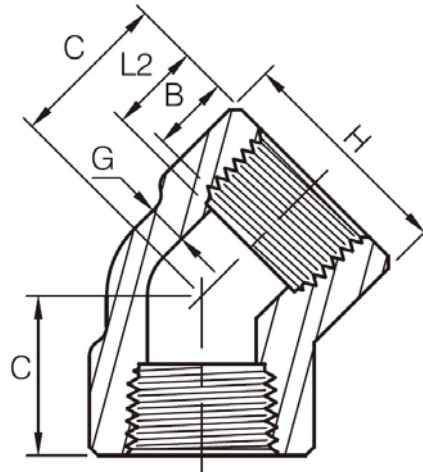

DN	Nom. Pipe Size	Center to End C			Outside Diameter Of Band H			Minimum Wall Thickness G			Length of Thread (Min)	
		2M	3M	6M	2M	3M	6M	2M	3M	6M	B <sup>(1)</sup>	L2 <sup>(1)</sup>
6	1/8"	17	17	19	22	22	25	3.18	3.18	6.35	6.4	6.7
8	1/4"	17	19	22	22	25	33	3.18	3.30	6.60	8.1	10.2
10	3/8"	19	22	25	25	33	38	3.18	3.51	6.98	9.1	10.4
15	1/2"	22	25	28	33	38	46	3.18	4.09	8.15	10.9	13.6
20	3/4"	25	28	33	38	46	56	3.18	4.32	8.53	12.7	13.9
25	1"	28	33	35	46	56	62	3.68	4.98	9.93	14.7	17.3
32	1-1/4"	33	35	43	56	62	75	3.89	5.28	10.59	17.0	18.0
40	1-1/2"	35	43	44	62	75	84	4.01	5.56	11.07	17.8	18.4
50	2"	43	44	52	75	84	102	4.27	7.14	12.09	19.0	19.2
65	2-1/2"	52	52	64	92	102	121	5.61	7.65	15.29	23.6	28.9
80	3"	64	64	79	109	121	146	5.99	8.84	16.64	25.9	30.5
100	4"	79	79	79	146	152	152	6.55	11.18	18.67	27.7	33.0

(1) Dimension B is minimum length of perfect thread. The length of useful thread (B plus threads with fully formed roots and flat crests) shall not be less than L2 (effective length of external thread) required by American National Standard for pipe threads (ANSI / ASME B1.20.1).

(2) 2M, 3M and 6M denote 2000Lb, 3000Lb and 6000Lb.

(3) Dimensions in accordance with ASME B16.11-2011.

## Street Elbow Threaded

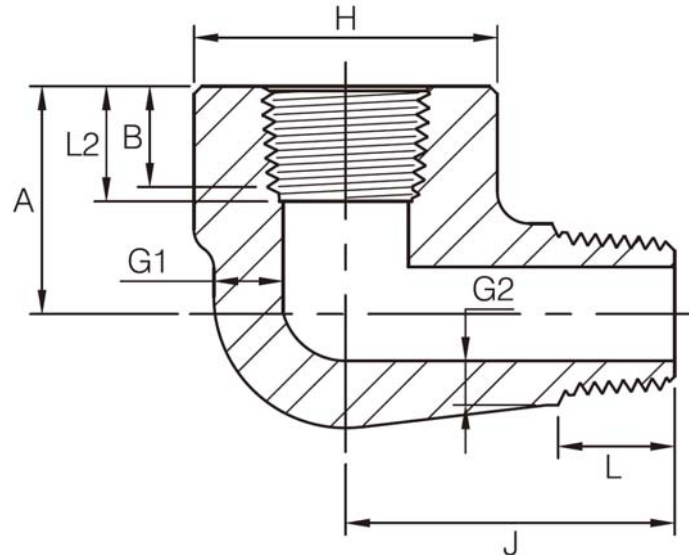

DN	Nom. Pipe Size	H		A		J		G1 (Min)		G2 <sup>(1)</sup> (Min)		B <sup>(2)</sup> (Min)	L2 <sup>(2)</sup> (Min)	L (Min)
		3M	6M	3M	6M	3M	6M	3M	6M	3M	6M			
6	1/8"	19	25	19	22	25	32	3.18	5.08	2.74	4.22	6.4	6.7	10.0
8	1/4"	25	32	22	25	32	38	3.30	5.66	3.22	5.28	8.1	10.2	11.0
10	3/8"	32	38	25	28	38	41	3.50	6.98	3.50	5.59	9.1	10.4	13.0
15	1/2"	38	44	28	35	41	48	4.09	8.15	4.16	6.53	10.9	13.6	14.0
20	3/4"	44	51	35	44	48	57	4.32	8.53	4.88	6.86	12.7	13.9	16.0
25	1"	51	62	44	51	57	66	4.98	9.93	5.56	7.95	14.7	17.3	19.0
32	1-1/4"	62	70	51	54	66	71	5.28	10.59	5.56	8.48	17.0	18.0	21.0
40	1-1/2"	70	84	54	64	71	84	5.56	11.07	6.25	8.89	17.8	18.4	21.0
50	2"	84	102	64	83	84	105	7.14	12.09	7.64	9.70	19.0	19.0	22.0

- (1) Wall thickness before threading.
- (2) Dimension B is minimum length of perfect thread. The length of useful thread (B plus threads with fully formed roots and flat crests) shall not be less than L2 (effective length of external thread) required by American National Standard for pipe threads (ANSI / ASME B1.20.1).
- (3) 3M and 6M denote 3000Lb and 6000Lb.
- (4) Dimensions in accordance with ASME B16.11-2011.

## Tee Threaded

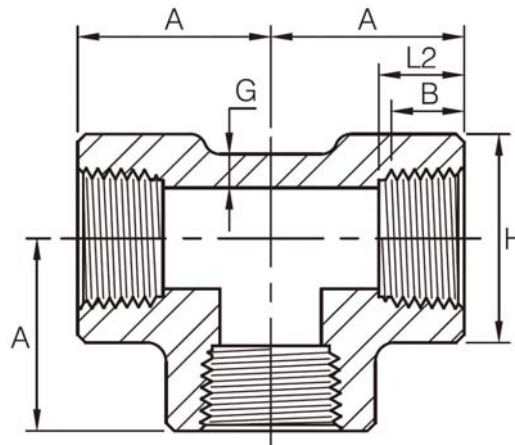

DN	Nom. Pipe Size	Center to End A			Outside Diameter Of Band H			Minimum Wall Thickness G			Length of Thread (Min)	
		2M	3M	6M	2M	3M	6M	2M	3M	6M	B <sup>(1)</sup>	L2 <sup>(1)</sup>
6	1/8"	21	21	25	22	22	25	3.18	3.18	6.35	6.4	6.7
8	1/4"	21	25	28	22	25	33	3.18	3.30	6.60	8.1	10.2
10	3/8"	25	28	33	25	33	38	3.18	3.51	6.98	9.1	10.4
15	1/2"	28	33	38	33	38	46	3.18	4.09	8.15	10.9	13.6
20	3/4"	33	38	44	38	46	56	3.18	4.32	8.53	12.7	13.9
25	1"	38	44	51	46	56	62	3.68	4.98	9.93	14.7	17.3
32	1-1/4"	44	51	60	56	62	75	3.89	5.28	10.59	17.0	18.0
40	1-1/2"	51	60	64	62	75	84	4.01	5.56	11.07	17.8	18.4
50	2"	60	64	83	75	84	102	4.27	7.14	12.09	19.0	19.2
65	2-1/2"	76	83	95	92	102	121	5.61	7.65	15.29	23.6	28.9
80	3"	86	95	106	109	121	146	5.99	8.84	16.64	25.9	30.5
100	4"	106	114	114	146	152	152	6.55	11.18	18.67	27.7	33.0

- (1) Dimension B is minimum length of perfect thread. The length of useful thread (B plus threads with fully formed roots and flat crests) shall not be less than L2 (effective length of external thread) required by American National Standard for pipe threads (ANSI / ASME B1.20.1).
- (2) 2M, 3M and 6M denote 2000Lb, 3000Lb and 6000Lb.
- (3) Dimensions in accordance with ASME B16.11-2011.



## 45° Lateral Tee Threaded

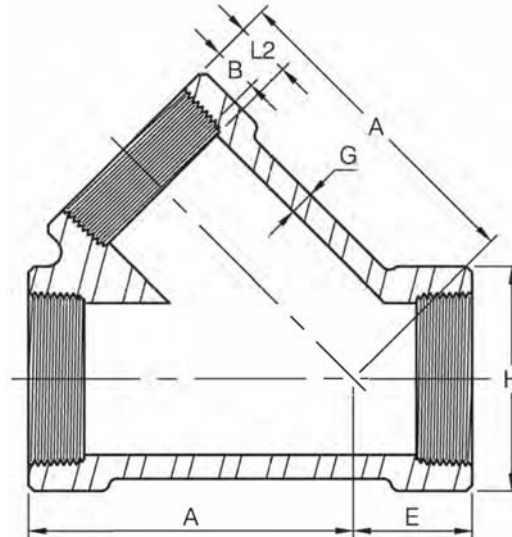

Nom. Pipe Size	A		E		G (Min)		H		Length of Thread (Min)	
	2000Lb	3000Lb	2000Lb	3000Lb	2000Lb	3000Lb	2000Lb	3000Lb	B <sup>(1)</sup>	L2 <sup>(1)</sup>
1/2"	46	55	20	23	3.18	4.09	33	38	10.9	13.6
3/4"	55	65	23	26	3.18	4.32	38	46	12.7	13.9
1"	65	73	26	31	3.68	4.98	46	56	14.7	17.3
1-1/4"	73	82	31	35	3.89	5.28	56	62	17.0	18.0
1-1/2"	82	113	35	42	4.01	5.56	62	75	17.8	18.4
2"	113	136	42	56	4.27	7.14	75	84	19.0	19.2
2-1/2"	136	-	56	-	5.61	-	92	-	23.6	28.9

- (1) Dimension B is minimum length of perfect thread. The length of useful thread (B plus threads with fully formed roots and flat crests) shall not be less than L2 (effective length of external thread) required by American National Standard for pipe threads (ANSI / ASME B1.20.1).
- (2) Dimensions in accordance with ASME B16.11-2011.

## Cross Threaded

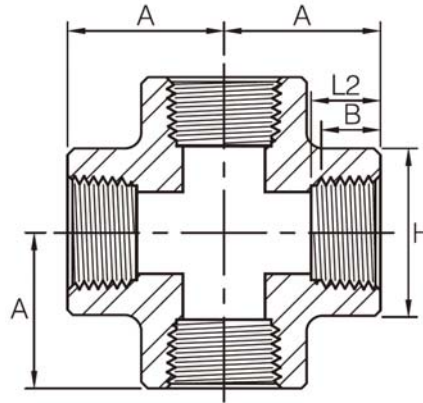

DN	Nom. Pipe Size	Center to End A			Outside Diameter Of Band H			Minimum Wall Thickness G			Length of Thread (Min)	
		2M	3M	6M	2M	3M	6M	2M	3M	6M	B <sup>(1)</sup>	L2 <sup>(1)</sup>
6	1/8"	21	21	25	22	22	25	3.18	3.18	6.35	6.4	6.7
8	1/4"	21	25	28	22	25	33	3.18	3.30	6.60	8.1	10.2
10	3/8"	25	28	33	25	33	38	3.18	3.51	6.98	9.1	10.4
15	1/2"	28	33	38	33	38	46	3.18	4.09	8.15	10.9	13.6
20	3/4"	33	38	44	38	46	56	3.18	4.32	8.53	12.7	13.9
25	1"	38	44	51	46	56	62	3.68	4.98	9.93	14.7	17.3
32	1-1/4"	44	51	60	56	62	75	3.89	5.28	10.59	17.0	18.0
40	1-1/2"	51	60	64	62	75	84	4.01	5.56	11.07	17.8	18.4
50	2"	60	64	83	75	84	102	4.27	7.14	12.09	19.0	19.2
65	2-1/2"	76	83	95	92	102	121	5.61	7.65	15.29	23.6	28.9
80	3"	86	95	106	109	121	146	5.99	8.84	16.64	25.9	30.5
100	4"	106	114	114	146	152	152	6.55	11.18	18.67	27.7	33.0

- (1) Dimension B is minimum length of perfect thread. The length of useful thread (B plus threads with fully formed roots and flat crests) shall not be less than L2 (effective length of external thread) required by American National Standard for pipe threads (ANSI / ASME B1.20.1).
- (2) 2M, 3M and 6M denote 2000Lb, 3000Lb and 6000Lb.
- (3) Dimensions in accordance with ASME B16.11-2011.

## Full Coupling Threaded

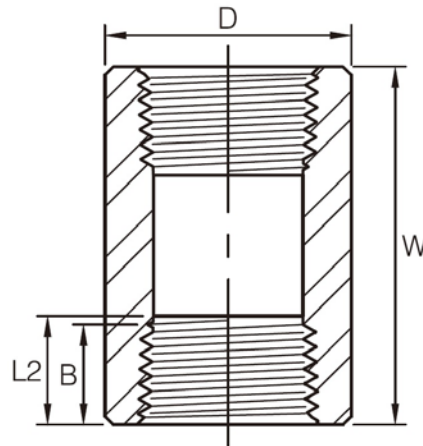

DN	Nom. Pipe Size	End to End Coupling W	Outside Diameter D		Length of Thread (Min)	
			3000Lb	6000Lb	B <sup>(1)</sup>	L2 <sup>(1)</sup>
6	1/8"	32	16	22	6.4	6.7
8	1/4"	35	19	25	8.1	10.2
10	3/8"	38	22	32	9.1	10.4
15	1/2"	48	28	38	10.9	13.6
20	3/4"	51	35	44	12.7	13.9
25	1"	60	44	57	14.7	17.3
32	1-1/4"	67	57	64	17.0	18.0
40	1-1/2"	79	64	76	17.8	18.4
50	2"	86	76	92	19.0	19.2
65	2-1/2"	92	92	108	23.6	28.9
80	3"	108	108	127	25.9	30.5
100	4"	121	140	159	27.7	33.0

(1) Dimension B is minimum length of perfect thread. The length of useful thread (B plus threads with fully formed roots and flat crests) shall not be less than L2 (effective length of external thread) required by American National Standard for pipe threads (ANSI / ASME B1.20.1).

(2) Dimensions in accordance with ASME B16.11-2011.



Half Coupling Threaded

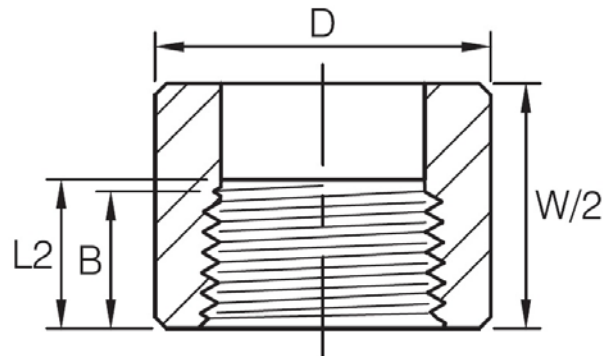

DN	Nom. Pipe Size	End to End Coupling W	Outside Diameter D		Length of Thread (Min)	
			3000Lb	6000Lb	B <sup>(1)</sup>	L2 <sup>(1)</sup>
6	1/8"	32	16	22	6.4	6.7
8	1/4"	35	19	25	8.1	10.2
10	3/8"	38	22	32	9.1	10.4
15	1/2"	48	28	38	10.9	13.6
20	3/4"	51	35	44	12.7	13.9
25	1"	60	44	57	14.7	17.3
32	1-1/4"	67	57	64	17.0	18.0
40	1-1/2"	79	64	76	17.8	18.4
50	2"	86	76	92	19.0	19.2
65	2-1/2"	92	92	108	23.6	28.9
80	3"	108	108	127	25.9	30.5
100	4"	121	140	159	27.7	33.0

- (1) Dimension B is minimum length of perfect thread. The length of useful thread (B plus threads with fully formed roots and flat crests) shall not be less than L2 (effective length of external thread) required by American National Standard for pipe threads (ANSI / ASME B1.20.1).
- (2) Dimensions in accordance with ASME B16.11-2011.

## Reducing Coupling Threaded

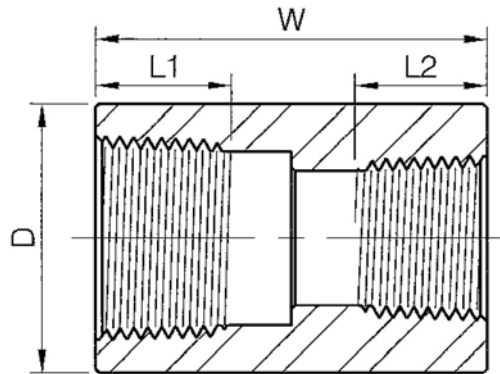

Nom. Pipe Size	D		W	L1	L2
	3000Lb	6000Lb			
1/4"x1/8"	19.0	25.0	35.0	11.4	8.8
3/8"x1/8"	22.0	32.0	38.0	12.4	8.8
3/8"x1/4"	22.0	32.0	38.0	12.4	11.4
1/2"x1/8"	28.0	38.0	48.0	14.9	8.8
1/2"x1/4"	28.0	38.0	48.0	14.9	11.4
1/2"x3/8"	28.0	38.0	48.0	14.9	12.4
3/4"x1/8"	35.0	44.0	51.0	16.8	8.8
3/4"x1/4"	35.0	44.0	51.0	16.8	11.4
3/4"x3/8"	35.0	44.0	51.0	16.8	12.4
3/4"x1/2"	35.0	44.0	51.0	16.8	14.9
1"x1/8"	44.0	57.0	51.0	19.6	8.8
1x1/4"	44.0	57.0	60.0	19.6	11.4
1"x3/8"	44.0	57.0	60.0	19.6	12.4
1"x1/2"	44.0	57.0	60.0	19.6	14.9
1"x3/4"	44.0	57.0	60.0	19.6	16.8
1-1/4"x1/8"	57.0	64.0	67.0	21.9	8.8
1-1/4"x1/4"	57.0	64.0	67.0	21.9	11.4
1-1/4"x3/8"	57.0	64.0	67.0	21.9	12.4
1-1/4"x1/2"	57.0	64.0	67.0	21.9	14.9
1-1/4"x3/4"	57.0	64.0	67.0	21.9	16.8
1-1/4"x1"	57.0	64.0	67.0	21.9	19.6
1-1/2"x1/8"	64.0	76.0	79.0	22.7	8.8
1-1/2"x1/4"	64.0	76.0	79.0	22.7	11.4
1-1/2"x3/8"	64.0	76.0	79.0	22.7	12.4
1-1/2"x1/2"	64.0	76.0	79.0	22.7	14.9
1-1/2"x3/4"	64.0	76.0	79.0	22.7	16.8
1-1/2"x1"	64.0	76.0	79.0	22.7	19.6
1-1/2"x1-1/4"	64.0	76.0	79.0	22.7	21.9
2"x1/8"	76.0	92.0	86.0	23.9	8.8
2"x1/4"	76.0	92.0	86.0	23.9	11.4
2"x3/8"	76.0	92.0	86.0	23.9	12.4
2"x1/2"	76.0	92.0	86.0	23.9	14.9
2"x3/4"	76.0	92.0	86.0	23.9	16.8
2"x1"	76.0	92.0	86.0	23.9	19.6

Reducing Coupling Threaded

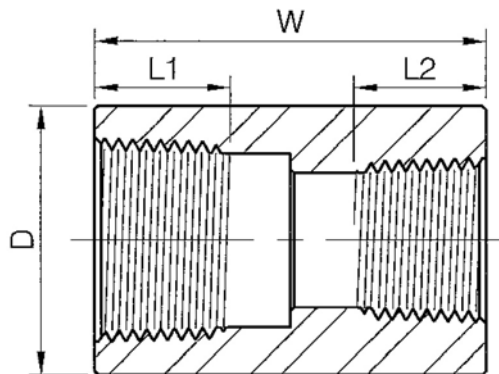

Nom. Pipe Size	D		W	L1	L2
	3000Lb	6000Lb			
2"x1-1/4"	76.0	92.0	86.0	23.9	21.9
2"x1-1/2"	76.0	92.0	86.0	23.9	22.7
2-1/2"x1/8"	92.0	108.0	92.0	30.5	8.8
2-1/2"x1/4"	92.0	108.0	92.0	30.5	11.4
2-1/2"x3/8"	92.0	108.0	92.0	30.5	12.4
2-1/2"x1/2"	92.0	108.0	92.0	30.5	14.9
2-1/2"x3/4"	92.0	108.0	92.0	30.5	16.8
2-1/2"x1"	92.0	108.0	92.0	30.5	19.6
2-1/2"x1-1/4"	92.0	108.0	92.0	30.5	21.9
2-1/2"x1-1/2"	92.0	108.0	92.0	30.5	22.7
2-1/2"x2"	92.0	108.0	92.0	30.5	23.9
3"x1/8"	108.0	127.0	108.0	32.8	8.8
3"x1/4"	108.0	127.0	108.0	32.8	11.4
3"x3/8"	108.0	127.0	108.0	32.8	12.4
3"x1/2"	108.0	127.0	108.0	32.8	14.9
3"x3/4"	108.0	127.0	108.0	32.8	16.8
3"x1"	108.0	127.0	108.0	32.8	19.6
3"x1-1/4"	108.0	127.0	108.0	32.8	21.9
3"x1-1/2"	108.0	127.0	108.0	32.8	22.7
3"x2"	108.0	127.0	108.0	32.8	23.9
3"x2-1/2"	108.0	127.0	108.0	32.8	30.5
4"x1/8"	140.0	159.0	121.0	34.6	8.8
4"x1/4"	140.0	159.0	121.0	34.6	11.4
4"x3/8"	140.0	159.0	121.0	34.6	12.4
4"x1/2"	140.0	159.0	121.0	34.6	14.9
4"x3/4"	140.0	159.0	121.0	34.6	16.8
4"x1"	140.0	159.0	121.0	34.6	19.6
4"x1-1/4"	140.0	159.0	121.0	34.6	21.9
4"x1-1/2"	140.0	159.0	121.0	34.6	22.7
4"x2"	140.0	159.0	121.0	34.6	23.9
4"x2-1/2"	140.0	159.0	121.0	34.6	30.5
4"x3"	140.0	159.0	121.0	34.6	32.8

(1) Dimensions in accordance with ASME B16.11-2011.

## Couplet Threaded

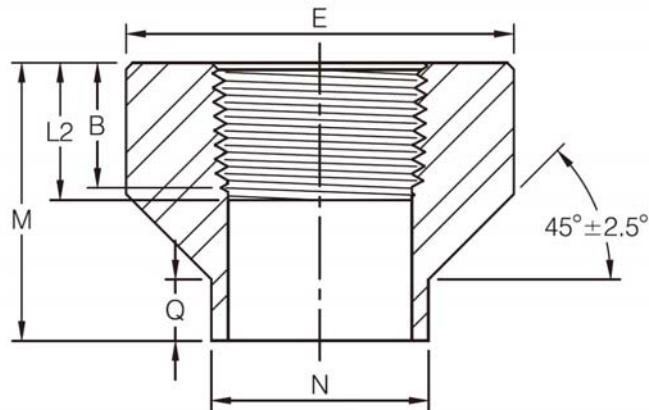

DN	Nom. Pipe Size	N	Q	M	E		Length of Thread (Min)	
					3000Lb	6000Lb	B <sup>(1)</sup>	L2 <sup>(1)</sup>
8	1/4"	17.5	9.5	30.2	23.8	25.4	8.1	10.2
10	3/8"	20.7	9.5	30.2	27.0	31.8	9.1	10.4
15	1/2"	23.8	9.5	33.4	33.4	38.1	10.9	13.6
20	3/4"	27.0	9.5	34.9	38.1	44.5	12.7	13.9
25	1"	33.4	9.5	42.9	46.1	57.2	14.7	17.3
32	1-1/4"	42.9	9.5	47.6	55.6	63.5	17.0	18.0
40	1-1/2"	49.2	9.5	50.8	63.5	76.2	17.8	18.4
50	2"	61.9	9.5	57.2	79.4	92.1	19.0	19.2
65	2-1/2"	73.0	9.5	63.5	92.1	108.0	23.6	28.9
80	3"	88.9	9.5	69.9	111.1	127.0	25.9	30.5
100	4"	114.3	9.5	76.2	141.3	158.8	27.7	33.0

- (1) Dimension B is minimum length of perfect thread. The length of useful thread (B plus threads with fully formed roots and flat crests) shall not be less than L2 (effective length of external thread) required by American National Standard for pipe threads (ANSI / ASME B1.20.1).
- (2) Dimensions in accordance with ASME B16.11-2011.

## Cap Threaded

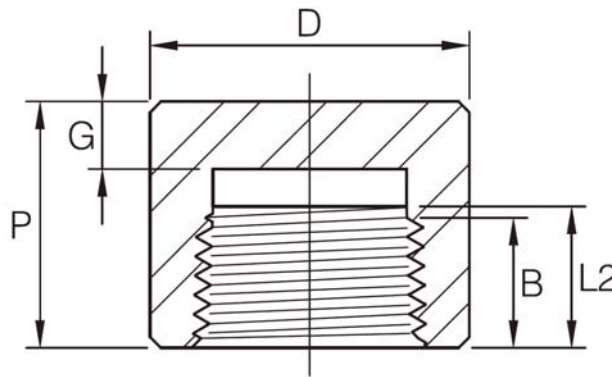

DN	Nom. Pipe Size	End to End P		Outside Diameter D		End Wall Thickness G (Min)		Length of Thread (Min)	
		3000Lb	6000Lb	3000Lb	6000Lb	3000Lb	6000Lb	B <sup>(1)</sup>	L2 <sup>(1)</sup>
6	1/8"	19	-	16	-	4.8	-	6.4	6.7
8	1/4"	25	27	19	25	4.8	6.4	8.1	10.2
10	3/8"	25	27	22	32	4.8	6.4	9.1	10.4
15	1/2"	32	33	28	38	6.4	7.9	10.9	13.6
20	3/4"	37	38	35	44	6.4	7.9	12.7	13.9
25	1"	41	43	44	57	9.7	11.2	14.7	17.3
32	1-1/4"	44	46	57	64	9.7	11.2	17.0	18.0
40	1-1/2"	44	48	64	76	11.2	12.7	17.8	18.4
50	2"	48	51	76	92	12.7	15.7	19.0	19.2
65	2-1/2"	60	64	92	108	15.7	19.0	23.6	28.9
80	3"	65	68	108	127	19.0	22.4	25.9	30.5
100	4"	68	75	140	159	22.4	28.4	27.7	33.0

- (1) Dimension B is minimum length of perfect thread. The length of useful thread (B plus threads with fully formed roots and flat crests) shall not be less than L2 (effective length of external thread) required by American National Standard for pipe threads (ANSI / ASME B1.20.1).
- (2) Dimensions in accordance with ASME B16.11-2011.

**Square Head Plug Threaded**

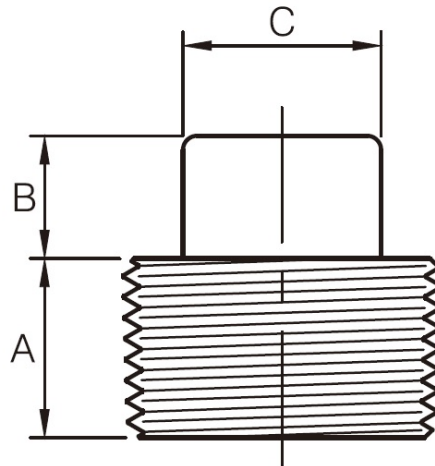

DN	Nom. Pipe Size	Length (Min) A	Height of Square (Min) B	Width Flat (Min) C
6	1/8"	10	6	7.15
8	1/4"	11	6	9.55
10	3/8"	13	8	11.11
15	1/2"	14	10	14.29
20	3/4"	16	11	15.88
25	1"	19	13	20.64
32	1-1/4"	21	14	23.81
40	1-1/2"	21	16	28.58
50	2"	22	18	33.34
65	2-1/2"	27	19	38.10
80	3"	28	21	42.86
100	4"	32	25	63.50

(1) Dimensions in accordance with ASME B16.11-2011.



**Round Head Plug Threaded**

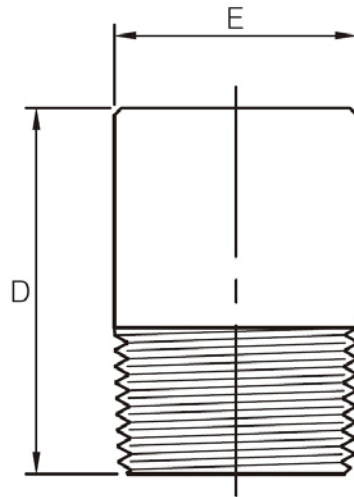

DN	Nom. Pipe Size	Diameter of Head (Nom.) E	Length (Min) D
6	1/8"	10	35
8	1/4"	14	41
10	3/8"	18	41
15	1/2"	21	44
20	3/4"	27	44
25	1"	33	51
32	1-1/4"	43	51
40	1-1/2"	48	51
50	2"	60	64
65	2-1/2"	73	70
80	3"	89	70
100	4"	114	76

(1) Dimensions in accordance with ASME B16.11-2011.

## Hex Head Plug Threaded

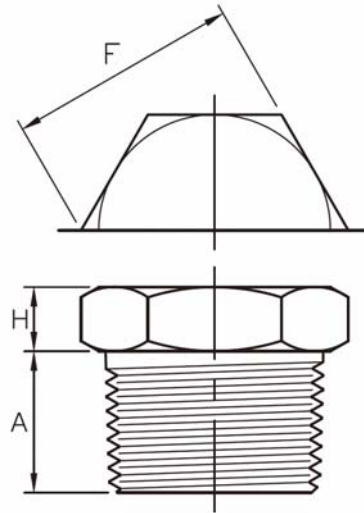

DN	Nom. Pipe Size	Length (Min) A	Width Flat (Nom.) F	Hex Height (Min) H
6	1/8"	10	11.11	6
8	1/4"	11	15.88	6
10	3/8"	13	17.46	8
15	1/2"	14	22.23	8
20	3/4"	16	26.99	10
25	1"	19	34.93	10
32	1-1/4"	21	44.45	14
40	1-1/2"	21	50.80	16
50	2"	22	63.50	18
65	2-1/2"	27	76.20	19
80	3"	28	88.90	21
100	4"	32	117.48	25

(1) Dimensions in accordance with ASME B16.11-2011.

## Bull Plug Threaded

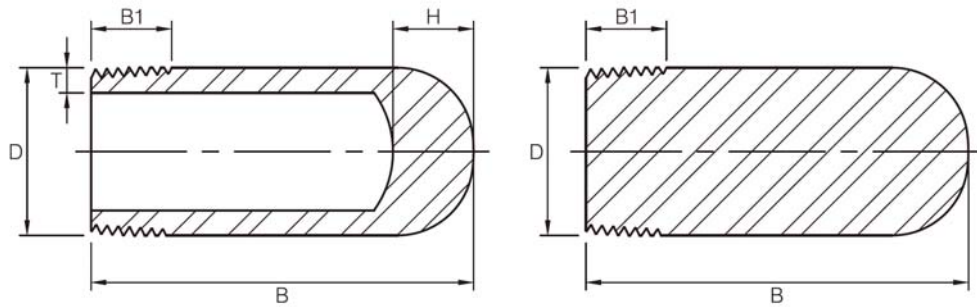

Nom. Pipe Size	D	B	B1	T (Min)				H
				Sch40/STD	Sch80/XS (3M)	Sch160 (6M)	XXS	
1/8"	10.3	51	9.5	1.73	2.41	-	-	14
1/4"	13.7	51	11.0	2.24	3.02	-	-	14
3/8"	17.1	57	12.5	2.31	3.20	-	-	14
1/2"	21.3	64	14.5	2.77	3.73	4.78	7.47	14
3/4"	26.7	70	16.0	2.87	3.91	5.56	7.82	18
1"	33.4	76	19.0	3.38	4.55	6.35	9.09	18
1-1/4"	42.2	83	20.5	3.56	4.85	6.35	9.70	18
1-1/2"	48.3	89	20.5	3.68	5.08	7.14	10.15	18
2"	60.3	102	22.0	3.91	5.54	8.74	11.07	20
2-1/2"	73.0	127	27.0	5.16	7.01	9.53	14.02	20
3"	88.9	152	28.5	5.49	7.62	11.13	15.24	20
4"	114.3	178	32.0	6.02	8.56	13.49	17.12	20

(1) Wall thickness (T Min.) in accordance with ASME B36.10M.

(2) Dimensions in accordance with MSS SP-95-2006.

**Hex Head Bushing Threaded**

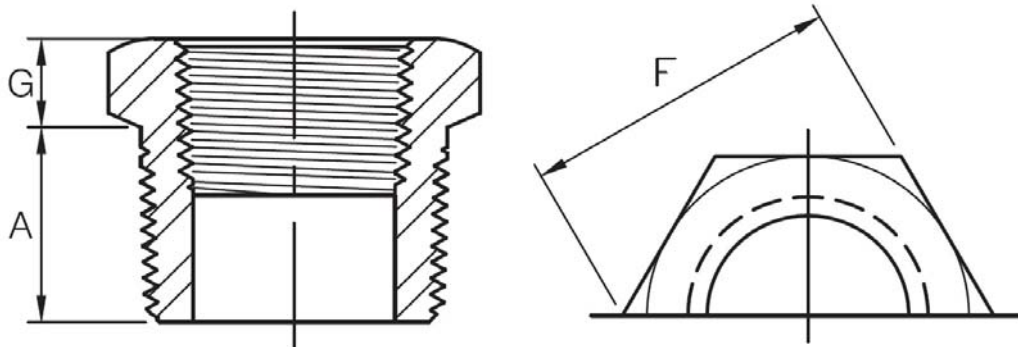

DN	Nom. Pipe Size	Length (Min) A	Width Flat (Nom.) F	Hex Height (Min) G
8	1/4"	11	15.88	3
10	3/8"	13	17.46	4
15	1/2"	14	22.23	5
20	3/4"	16	26.99	6
25	1"	19	34.93	6
32	1-1/4"	21	44.45	7
40	1-1/2"	21	50.80	8
50	2"	22	63.50	9
65	2-1/2"	27	76.20	10
80	3"	28	88.90	10
100	4"	32	117.48	13

- (1) Hex Head Bushings of one-size reduction should not be used in services where they might be subject to harmful loads and forces than internal pressure.
- (2) Dimensions in accordance with ASME B16.11-2011.

## Boss Threaded

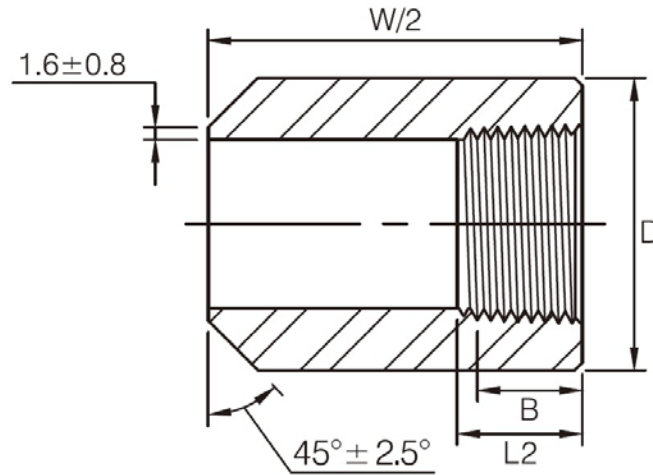

DN	Nom. Pipe Size	D		W		L2 (Min)	
		3000Lb	6000Lb	3000Lb	6000Lb	3000Lb	6000Lb
6	1/8"	16.0	22.0	38.0		6.70	
8	1/4"	19.0	26.0	41.0		10.21	
10	3/8"	22.0	32.0	45.0		10.36	
15	1/2"	29.0	38.0	51.0		13.56	
20	3/4"	35.0	45.0	51.0		13.86	
25	1"	45.0	60.0	51.0		17.34	
40	1-1/2"	64.0	76.0	51.0		18.38	
50	2"	76.0	95.0	51.0		19.22	
65	2-1/2"	95.0	-	51.0	-	28.89	-
80	3"	110.0	-	57.0	-	30.48	-
100	4"	140.0	-	64.0	-	33.02	-

(1) Dimensions in accordance with BS3799-1974.

## Hex Nipple Threaded

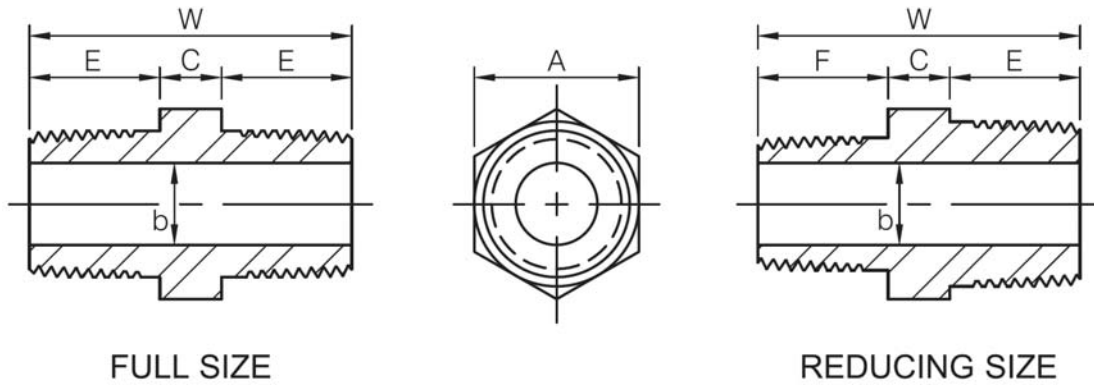

FULL SIZE

REDUCING SIZE

Nominal Size		A (Min)	W (Min)	E (Min)	b		C (Min)	F (Min)
DN	Inch				3000Lb	6000Lb		
6	1/8"	11	26	10	5	2	6	-
8	1/4"	15	36	15	8	6	6	-
8x6	1/4"x1/8"	15	31	15	5	2	6	10
10	3/8"	18	40	16	11	8	8	-
10x8	3/8"x1/4"	18	39	16	8	6	8	15
15	1/2"	22	48	20	14	11	8	-
15x10	1/2"x3/8"	22	44	20	11	8	8	16
15x8	1/2"x1/4"	22	43	20	8	6	8	15
20	3/4"	27	52	21	19	13	10	-
20x15	3/4"x1/2"	27	50	21	14	11	9	20
20x10	3/4"x3/8"	27	46	21	11	8	9	16
25	1"	35	60	25	24	17	10	-
25x20	1"x3/4"	35	56	25	19	13	10	21
25x15	1"x1/2"	35	55	25	14	11	10	20
40	1-1/2"	50	68	26	38	30	16	-
40x25	1-1/2"x1"	50	67	26	24	17	16	25
40x20	1-1/2"x3/4"	50	63	26	19	13	16	21
40x15	1-1/2"x1/2"	50	62	26	14	11	16	20
50	2"	62	71	27	49	39	17	-
50x40	2"x1-1/2"	62	70	27	38	30	17	26
50x25	2"x1"	62	70	27	24	17	18	25
50x20	2"x3/4"	62	65	27	19	13	17	21
50x15	2"x1/2"	62	65	27	14	11	18	20

(1) Dimensions in accordance with BS3799-1974.



## Pipe Nipple Threaded

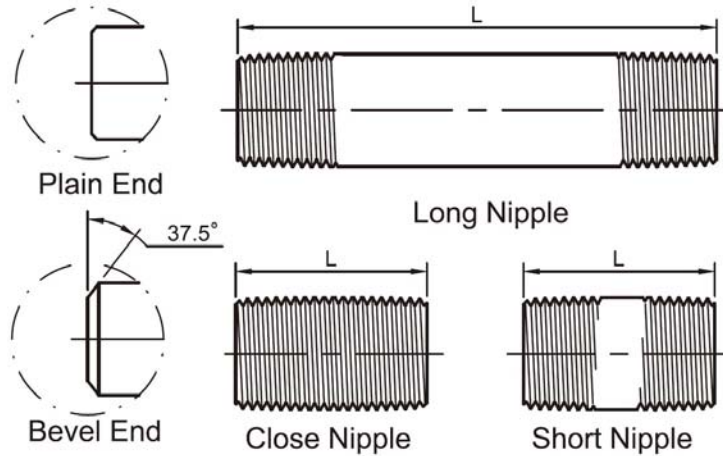

Nom. Pipe Size	L			Plain End Weight (kg/m)			
	Close Nipple	Short Nipple	Long Nipple	Sch40/ST D	Sch80/XS	Sch160	XXS
1/8"	3/4"	1-1/2"	2"~12"	0.37	0.47	-	-
1/4"	7/8"	1-1/2"	2"~12"	0.63	0.8	-	-
3/8"	1"	1-1/2"	2"~12"	0.84	1.1	-	-
1/2"	1-1/8"	1-1/2"	2"~12"	1.27	1.62	1.95	2.55
3/4"	1-3/8"	2"	2-1/2"~12"	1.69	2.2	2.9	3.64
1"	1-1/2"	2"	2-1/2"~12"	2.5	3.24	4.24	5.45
1-1/4"	1-5/8"	2-1/2"	3"~12"	3.39	4.47	5.61	7.77
1-1/2"	1-3/4"	2-1/2"	3"~12"	4.05	5.41	7.25	9.55
2"	2"	2-1/2"	3"~12"	5.44	7.48	11.11	13.44
2-1/2"	2-1/2"	3"	3-1/2"~12"	8.63	11.41	14.92	20.39
3"	2-5/8"	3"	3-1/2"~12"	11.29	15.27	21.35	27.68
3-1/2"	2-3/4"	4"	4-1/2"~12"	13.57	18.64	-	-
4"	2-7/8"	4"	4-1/2"~12"	16.08	22.32	33.54	41.03
5"	3"	4-1/2"	5"~12"	21.77	30.97	49.12	57.43
6"	3-1/8"	4-1/2"	5"~12"	28.26	42.56	67.57	79.22

- (1) Specifications in accordance with ASTM A733-2016.
- (2) Weld bevel in accordance with ASME B16.25.

## Shape of Thread

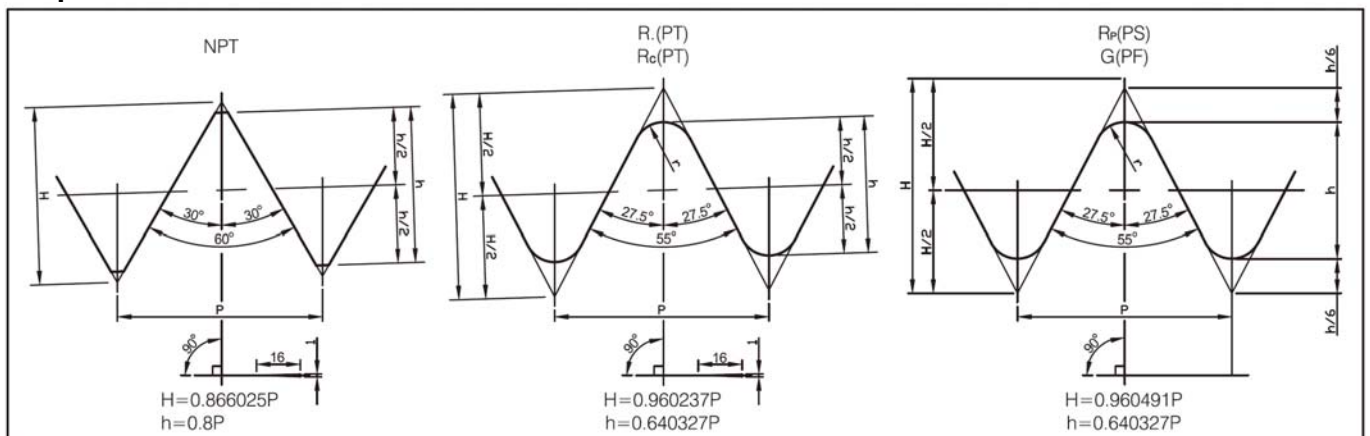

## Concentric Swage Nipple

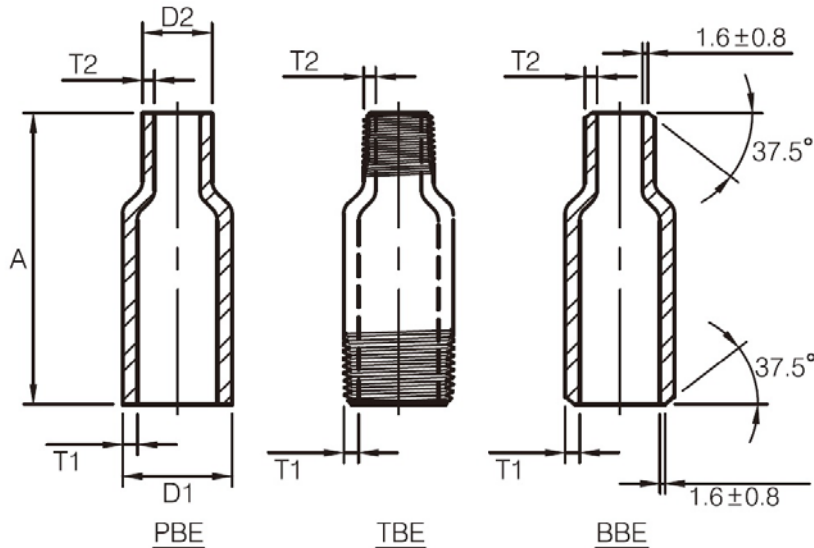

Nom. Pipe Size	Outside Diameter		Wall Thickness								
	Large End D1	Small End D2	T1					T2			
			End To End "A"	Sch40 (STD)	Sch80 (XS)	Sch160	XXS	Sch40 (STD)	Sch80 (XS)	Sch160	XXS
1/4"x1/8"	13.7	10.3	57	2.2	3.0	3.7	6.1	1.7	2.4	-	-
3/8"x1/8"	17.1	10.3	64	2.3	3.2	4.0	6.4	1.7	2.4	-	-
3/8"x1/4"	17.1	13.7	64	2.3	3.2	4.0	6.4	2.2	3.0	-	-
1/2"x1/8"	21.3	10.3	70	2.8	3.7	4.8	7.5	1.7	2.4	-	-
1/2"x1/4"	21.3	13.7	70	2.8	3.7	4.8	7.5	2.2	3.0	-	-
1/2"x3/8"	21.3	17.1	70	2.8	3.7	4.8	7.5	2.3	3.2	-	-
3/4"x1/8"	26.7	10.3	76	2.9	3.9	5.6	7.8	1.7	2.4	-	-
3/4"x1/4"	26.7	13.7	76	2.9	3.9	5.6	7.8	2.2	3.0	-	-
3/4"x3/8"	26.7	17.1	76	2.9	3.9	5.6	7.8	2.3	3.2	-	-
3/4"x1/2"	26.7	21.3	76	2.9	3.9	5.6	7.8	2.8	3.7	4.8	7.5
1"x1/8"	33.4	10.3	89	3.4	4.5	6.4	9.1	1.7	2.4	-	-
1"x1/4"	33.4	13.7	89	3.4	4.5	6.4	9.1	2.2	3.0	-	-
1"x3/8"	33.4	17.1	89	3.4	4.5	6.4	9.1	2.3	3.2	-	-
1"x1/2"	33.4	21.3	89	3.4	4.5	6.4	9.1	2.8	3.7	4.8	7.5
1"x3/4"	33.4	26.7	89	3.4	4.5	6.4	9.1	2.9	3.9	5.6	7.8
1-1/4"x1/8"	42.2	10.3	102	3.6	4.9	6.4	9.7	1.7	2.4	-	-
1-1/4"x1/4"	42.2	13.7	102	3.6	4.9	6.4	9.7	2.2	3.0	-	-
1-1/4"x3/8"	42.2	17.1	102	3.6	4.9	6.4	9.7	2.3	3.2	-	-
1-1/4"x1/2"	42.2	21.3	102	3.6	4.9	6.4	9.7	2.8	3.7	4.8	7.5
1-1/4"x3/4"	42.2	26.7	102	3.6	4.9	6.4	9.7	2.9	3.9	5.6	7.8
1-1/4"x1"	42.2	33.4	102	3.6	4.9	6.4	9.7	3.4	4.5	6.4	9.1
1-1/2"x1/8"	48.3	10.3	114	3.7	5.1	7.1	10.2	1.7	2.4	-	-
1-1/2"x1/4"	48.3	13.7	114	3.7	5.1	7.1	10.2	2.2	3.0	-	-
1-1/2"x3/8"	48.3	17.1	114	3.7	5.1	7.1	10.2	2.3	3.2	-	-
1-1/2"x1/2"	48.3	21.3	114	3.7	5.1	7.1	10.2	2.8	3.7	4.8	7.5
1-1/2"x3/4"	48.3	26.7	114	3.7	5.1	7.1	10.2	2.9	3.9	5.6	7.8
1-1/2"x1"	48.3	33.4	114	3.7	5.1	7.1	10.2	3.4	4.5	6.4	9.1
1-1/2"x1-1/4"	48.3	42.2	114	3.7	5.1	7.1	10.2	3.6	4.9	6.4	9.7
2"x1/8"	60.3	10.3	165	3.9	5.5	8.7	11.1	1.7	2.4	-	-
2"x1/4"	60.3	13.7	165	3.9	5.5	8.7	11.1	2.2	3.0	-	-
2"x3/8"	60.3	17.1	165	3.9	5.5	8.7	11.1	2.3	3.2	-	-
2"x1/2"	60.3	21.3	165	3.9	5.5	8.7	11.1	2.8	3.7	4.8	7.5
2"x3/4"	60.3	26.7	165	3.9	5.5	8.7	11.1	2.9	3.9	5.6	7.8

## Concentric Swage Nipple

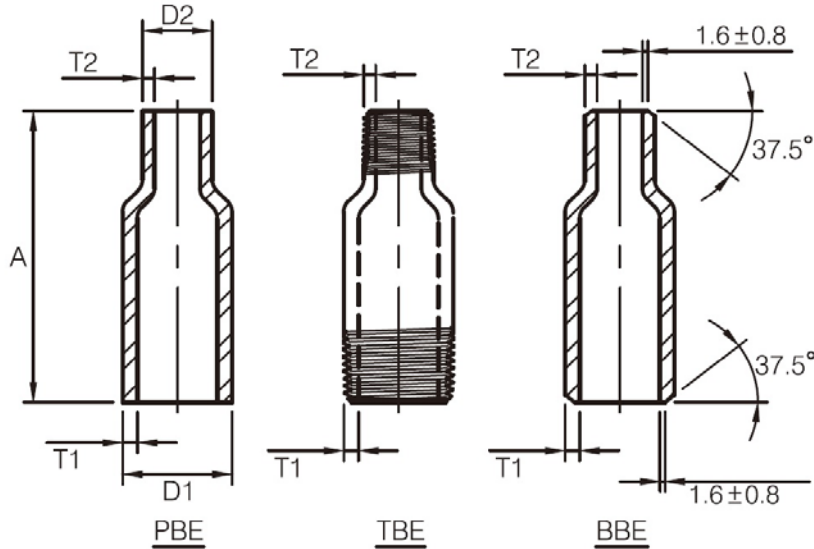

Nom. Pipe Size	Outside Diameter		Wall Thickness								
	Large End D1	Small End D2	T1				T2				
			End To End "A"	Sch40 (STD)	Sch80 (XS)	Sch160	XXS	Sch40 (STD)	Sch80 (XS)	Sch160	XXS
2"x1"	60.3	33.4	165	3.9	5.5	8.7	11.1	3.4	4.5	6.4	9.1
2"x1-1/4"	60.3	42.2	165	3.9	5.5	8.7	11.1	3.6	4.9	6.4	9.7
2"x1-1/2"	60.3	48.3	165	3.9	5.5	8.7	11.1	3.7	5.1	7.1	10.2
2-1/2"x1/8"	73.0	10.3	178	5.2	7.0	9.5	14.0	1.7	2.4	-	-
2-1/2"x1/4"	73.0	13.7	178	5.2	7.0	9.5	14.0	2.2	3.0	-	-
2-1/2"x3/8"	73.0	17.1	178	5.2	7.0	9.5	14.0	2.3	3.2	-	-
2-1/2"x1/2"	73.0	21.3	178	5.2	7.0	9.5	14.0	2.8	3.7	4.8	7.5
2-1/2"x3/4"	73.0	26.7	178	5.2	7.0	9.5	14.0	2.9	3.9	5.6	7.8
2-1/2"x1"	73.0	33.4	178	5.2	7.0	9.5	14.0	3.4	4.5	6.4	9.1
2-1/2"x1-1/4"	73.0	42.2	178	5.2	7.0	9.5	14.0	3.6	4.9	6.4	9.7
2-1/2"x1-1/2"	73.0	48.3	178	5.2	7.0	9.5	14.0	3.7	5.1	7.1	10.2
2-1/2"x2"	73.0	60.3	178	5.2	7.0	9.5	14.0	3.9	5.5	8.7	11.1
3"x1/8"	88.9	10.3	203	5.5	7.6	11.1	15.2	1.7	2.4	-	-
3"x1/4"	88.9	13.7	203	5.5	7.6	11.1	15.2	2.2	3.0	-	-
3"x3/8"	88.9	17.1	203	5.5	7.6	11.1	15.2	2.3	3.2	-	-
3"x1/2"	88.9	21.3	203	5.5	7.6	11.1	15.2	2.8	3.7	4.8	7.5
3"x3/4"	88.9	26.7	203	5.5	7.6	11.1	15.2	2.9	3.9	5.6	7.8
3"x1"	88.9	33.4	203	5.5	7.6	11.1	15.2	3.4	4.5	6.4	9.1
3"x1-1/4"	88.9	42.2	203	5.5	7.6	11.1	15.2	3.6	4.9	6.4	9.7
3"x1-1/2"	88.9	48.3	203	5.5	7.6	11.1	15.2	3.7	5.1	7.1	10.2
3"x2"	88.9	60.3	203	5.5	7.6	11.1	15.2	3.9	5.5	8.7	11.1
3"x2-1/2"	88.9	73.0	203	5.5	7.6	11.1	15.2	5.2	7.0	9.5	14.0
3-1/2"x1/8"	101.6	10.3	203	5.7	8.1	-	-	1.7	2.4	-	-
3-1/2"x1/4"	101.6	13.7	203	5.7	8.1	-	-	2.2	3.0	-	-
3-1/2"x3/8"	101.6	17.1	203	5.7	8.1	-	-	2.3	3.2	-	-
3-1/2"x1/2"	101.6	21.3	203	5.7	8.1	-	-	2.8	3.7	4.8	7.5
3-1/2"x3/4"	101.6	26.7	203	5.7	8.1	-	-	2.9	3.9	5.6	7.8
3-1/2"x1"	101.6	33.4	203	5.7	8.1	-	-	3.4	4.5	6.4	9.1
3-1/2"x1-1/4"	101.6	42.2	203	5.7	8.1	-	-	3.6	4.9	6.4	9.7
3-1/2"x1-1/2"	101.6	48.3	203	5.7	8.1	-	-	3.7	5.1	7.1	10.2
3-1/2"x2"	101.6	60.3	203	5.7	8.1	-	-	3.9	5.5	8.7	11.1
3-1/2"x2-1/2"	101.6	73.0	203	5.7	8.1	-	-	5.2	7.0	9.5	14.0
3-1/2"x3"	101.6	88.9	203	5.7	8.1	-	-	5.5	7.6	11.1	15.2

## Concentric Swage Nipple

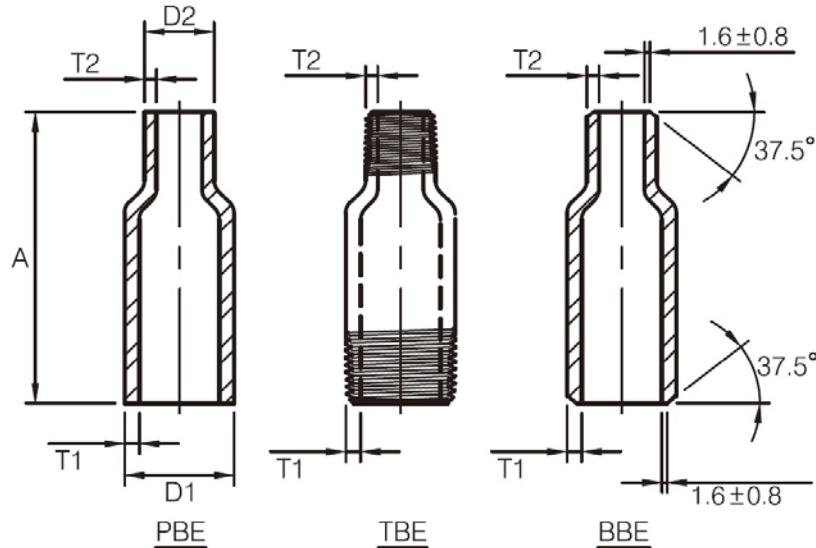

Nom. Pipe Size	Outside Diameter		Wall Thickness								
	Large End D1	Small End D2	T1					T2			
			End To End "A"	Sch40 (STD)	Sch80 (XS)	Sch160	XXS	Sch40 (STD)	Sch80 (XS)	Sch160	XXS
4"x1/4"	114.3	13.7	229	6.0	8.6	13.5	17.1	2.2	3.0	-	-
4"x3/8"	114.3	17.1	229	6.0	8.6	13.5	17.1	2.3	3.2	-	-
4"x1/2"	114.3	21.3	229	6.0	8.6	13.5	17.1	2.8	3.7	4.8	7.5
4"x3/4"	114.3	26.7	229	6.0	8.6	13.5	17.1	2.9	3.9	5.6	7.8
4"x1"	114.3	33.4	229	6.0	8.6	13.5	17.1	3.4	4.5	6.4	9.1
4"x1-1/4"	114.3	42.2	229	6.0	8.6	13.5	17.1	3.6	4.9	6.4	9.7
4"x1-1/2"	114.3	48.3	229	6.0	8.6	13.5	17.1	3.7	5.1	7.1	10.2
4"x2"	114.3	60.3	229	6.0	8.6	13.5	17.1	3.9	5.5	8.7	11.1
4"x2-1/2"	114.3	73.0	229	6.0	8.6	13.5	17.1	5.2	7.0	9.5	14.0
4"x3"	114.3	88.9	229	6.0	8.6	13.5	17.1	5.5	7.6	11.1	15.2
4"x3-1/2"	114.3	101.6	229	6.0	8.6	13.5	17.1	5.7	8.1	-	-

(1) Dimensions in accordance with MSS SP-95-2014.

(2) Wall Thickness (T1 & T2) in accordance with ASME B36.10M.

(3) Connection end types:

PBE : Plain Both Ends

PSE : Plain Small End

PLE : Plain Large End

BBE : Bevel Both Ends

BSE : Bevel Small End

BLE : Bevel Large End

TBE : Thread Both Ends

TSE : Thread Small End

TLE : Thread Large End

## Eccentric Swage Nipple

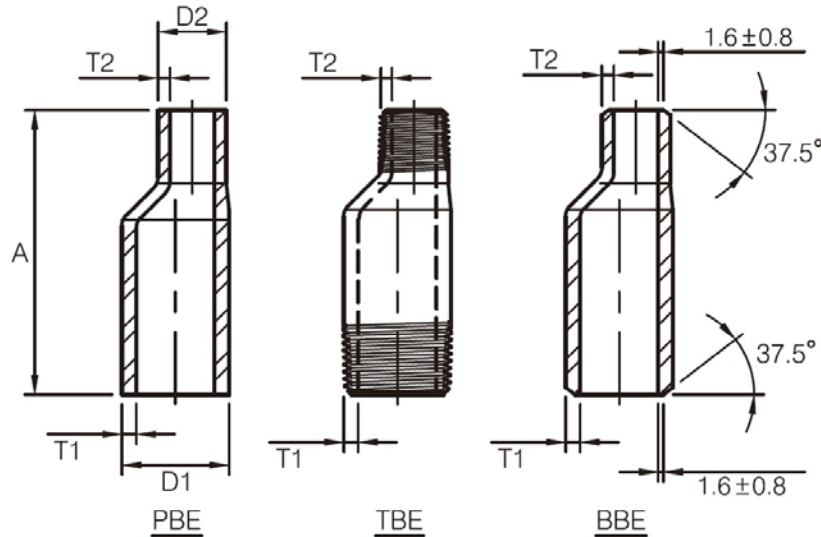

Nom. Pipe Size	Outside Diameter		Wall Thickness								
	Large End D1	Small End D2	T1				T2				
			End To End "A"	Sch40 (STD)	Sch80 (XS)	Sch160	XXS	Sch40 (STD)	Sch80 (XS)	Sch160	XXS
1/4"x1/8"	13.7	10.3	57	2.2	3.0	3.7	6.1	1.7	2.4	-	-
3/8"x1/8"	17.1	10.3	64	2.3	3.2	4.0	6.4	1.7	2.4	-	-
3/8"x1/4"	17.1	13.7	64	2.3	3.2	4.0	6.4	2.2	3.0	-	-
1/2"x1/8"	21.3	10.3	70	2.8	3.7	4.8	7.5	1.7	2.4	-	-
1/2"x1/4"	21.3	13.7	70	2.8	3.7	4.8	7.5	2.2	3.0	-	-
1/2"x3/8"	21.3	17.1	70	2.8	3.7	4.8	7.5	2.3	3.2	-	-
3/4"x1/8"	26.7	10.3	76	2.9	3.9	5.6	7.8	1.7	2.4	-	-
3/4"x1/4"	26.7	13.7	76	2.9	3.9	5.6	7.8	2.2	3.0	-	-
3/4"x3/8"	26.7	17.1	76	2.9	3.9	5.6	7.8	2.3	3.2	-	-
3/4"x1/2"	26.7	21.3	76	2.9	3.9	5.6	7.8	2.8	3.7	4.8	7.5
1"x1/8"	33.4	10.3	89	3.4	4.5	6.4	9.1	1.7	2.4	-	-
1"x1/4"	33.4	13.7	89	3.4	4.5	6.4	9.1	2.2	3.0	-	-
1"x3/8"	33.4	17.1	89	3.4	4.5	6.4	9.1	2.3	3.2	-	-
1"x1/2"	33.4	21.3	89	3.4	4.5	6.4	9.1	2.8	3.7	4.8	7.5
1"x3/4"	33.4	26.7	89	3.4	4.5	6.4	9.1	2.9	3.9	5.6	7.8
1-1/4"x1/8"	42.2	10.3	102	3.6	4.9	6.4	9.7	1.7	2.4	-	-
1-1/4"x1/4"	42.2	13.7	102	3.6	4.9	6.4	9.7	2.2	3.0	-	-
1-1/4"x3/8"	42.2	17.1	102	3.6	4.9	6.4	9.7	2.3	3.2	-	-
1-1/4"x1/2"	42.2	21.3	102	3.6	4.9	6.4	9.7	2.8	3.7	4.8	7.5
1-1/4"x3/4"	42.2	26.7	102	3.6	4.9	6.4	9.7	2.9	3.9	5.6	7.8
1-1/4"x1"	42.2	33.4	102	3.6	4.9	6.4	9.7	3.4	4.5	6.4	9.1
1-1/2"x1/8"	48.3	10.3	114	3.7	5.1	7.1	10.2	1.7	2.4	-	-
1-1/2"x1/4"	48.3	13.7	114	3.7	5.1	7.1	10.2	2.2	3.0	-	-
1-1/2"x3/8"	48.3	17.1	114	3.7	5.1	7.1	10.2	2.3	3.2	-	-
1-1/2"x1/2"	48.3	21.3	114	3.7	5.1	7.1	10.2	2.8	3.7	4.8	7.5
1-1/2"x3/4"	48.3	26.7	114	3.7	5.1	7.1	10.2	2.9	3.9	5.6	7.8
1-1/2"x1"	48.3	33.4	114	3.7	5.1	7.1	10.2	3.4	4.5	6.4	9.1
1-1/2"x1-1/4"	48.3	42.2	114	3.7	5.1	7.1	10.2	3.6	4.9	6.4	9.7
2"x1/8"	60.3	10.3	165	3.9	5.5	8.7	11.1	1.7	2.4	-	-
2"x1/4"	60.3	13.7	165	3.9	5.5	8.7	11.1	2.2	3.0	-	-
2"x3/8"	60.3	17.1	165	3.9	5.5	8.7	11.1	2.3	3.2	-	-
2"x1/2"	60.3	21.3	165	3.9	5.5	8.7	11.1	2.8	3.7	4.8	7.5
2"x3/4"	60.3	26.7	165	3.9	5.5	8.7	11.1	2.9	3.9	5.6	7.8
2"x1"	60.3	33.4	165	3.9	5.5	8.7	11.1	3.4	4.5	6.4	9.1

## Eccentric Swage Nipple

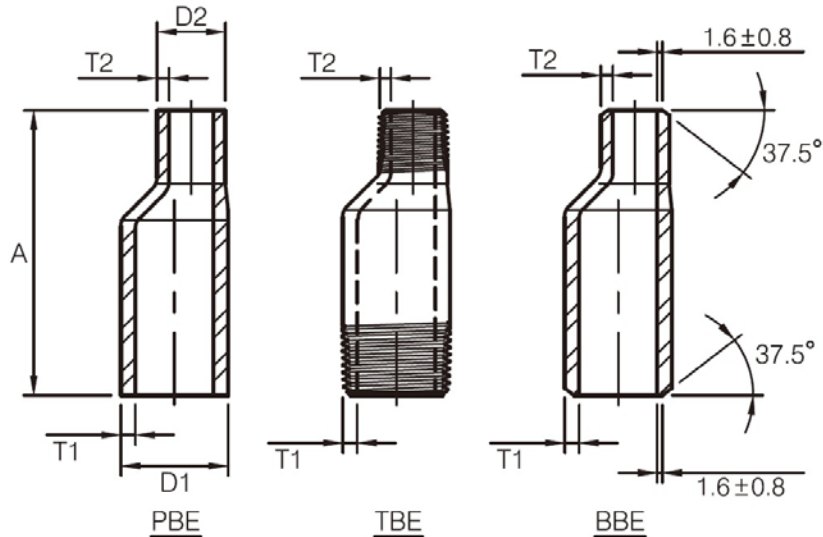

Nom. Pipe Size	Outside Diameter		Wall Thickness										
	Large End D1	Small End D2	End To End "A"	T1				T2					
				Sch40 (STD)	Sch80 (XS)	Sch160	XXS	Sch40 (STD)	Sch80 (XS)	Sch160	XXS		
2"x1-1/4"	60.3	42.2	165	3.9	5.5	8.7	11.1	3.6	4.9	6.4	9.7		
2"x1-1/2"	60.3	48.3	165	3.9	5.5	8.7	11.1	3.7	5.1	7.1	10.2		
2-1/2"x1/8"	73.0	10.3	178	5.2	7.0	9.5	14.0	1.7	2.4	-	-		
2-1/2"x1/4"	73.0	13.7	178	5.2	7.0	9.5	14.0	2.2	3.0	-	-		
2-1/2"x3/8"	73.0	17.1	178	5.2	7.0	9.5	14.0	2.3	3.2	-	-		
2-1/2"x1/2"	73.0	21.3	178	5.2	7.0	9.5	14.0	2.8	3.7	4.8	7.5		
2-1/2"x3/4"	73.0	26.7	178	5.2	7.0	9.5	14.0	2.9	3.9	5.6	7.8		
2-1/2"x1"	73.0	33.4	178	5.2	7.0	9.5	14.0	3.4	4.5	6.4	9.1		
2-1/2"x1-1/4"	73.0	42.2	178	5.2	7.0	9.5	14.0	3.6	4.9	6.4	9.7		
2-1/2"x1-1/2"	73.0	48.3	178	5.2	7.0	9.5	14.0	3.7	5.1	7.1	10.2		
2-1/2"x2"	73.0	60.3	178	5.2	7.0	9.5	14.0	3.9	5.5	8.7	11.1		
3"x1/8"	88.9	10.3	203	5.5	7.6	11.1	15.2	1.7	2.4	-	-		
3"x1/4"	88.9	13.7	203	5.5	7.6	11.1	15.2	2.2	3.0	-	-		
3"x3/8"	88.9	17.1	203	5.5	7.6	11.1	15.2	2.3	3.2	-	-		
3"x1/2"	88.9	21.3	203	5.5	7.6	11.1	15.2	2.8	3.7	4.8	7.5		
3"x3/4"	88.9	26.7	203	5.5	7.6	11.1	15.2	2.9	3.9	5.6	7.8		
3"x1"	88.9	33.4	203	5.5	7.6	11.1	15.2	3.4	4.5	6.4	9.1		
3"x1-1/4"	88.9	42.2	203	5.5	7.6	11.1	15.2	3.6	4.9	6.4	9.7		
3"x1-1/2"	88.9	48.3	203	5.5	7.6	11.1	15.2	3.7	5.1	7.1	10.2		
3"x2"	88.9	60.3	203	5.5	7.6	11.1	15.2	3.9	5.5	8.7	11.1		
3"x2-1/2"	88.9	73.0	203	5.5	7.6	11.1	15.2	5.2	7.0	9.5	14.0		
3-1/2"x1/8"	101.6	10.3	203	5.7	8.1	-	-	1.7	2.4	-	-		
3-1/2"x1/4"	101.6	13.7	203	5.7	8.1	-	-	2.2	3.0	-	-		
3-1/2"x3/8"	101.6	17.1	203	5.7	8.1	-	-	2.3	3.2	-	-		
3-1/2"x1/2"	101.6	21.3	203	5.7	8.1	-	-	2.8	3.7	4.8	7.5		
3-1/2"x3/4"	101.6	26.7	203	5.7	8.1	-	-	2.9	3.9	5.6	7.8		
3-1/2"x1"	101.6	33.4	203	5.7	8.1	-	-	3.4	4.5	6.4	9.1		
3-1/2"x1-1/4"	101.6	42.2	203	5.7	8.1	-	-	3.6	4.9	6.4	9.7		
3-1/2"x1-1/2"	101.6	48.3	203	5.7	8.1	-	-	3.7	5.1	7.1	10.2		
3-1/2"x2"	101.6	60.3	203	5.7	8.1	-	-	3.9	5.5	8.7	11.1		
3-1/2"x2-1/2"	101.6	73.0	203	5.7	8.1	-	-	5.2	7.0	9.5	14.0		
3-1/2"x3"	101.6	88.9	203	5.7	8.1	-	-	5.5	7.6	11.1	15.2		
4"x1/4"	114.3	13.7	229	6.0	8.6	13.5	17.1	2.2	3.0	-	-		



## Eccentric Swage Nipple

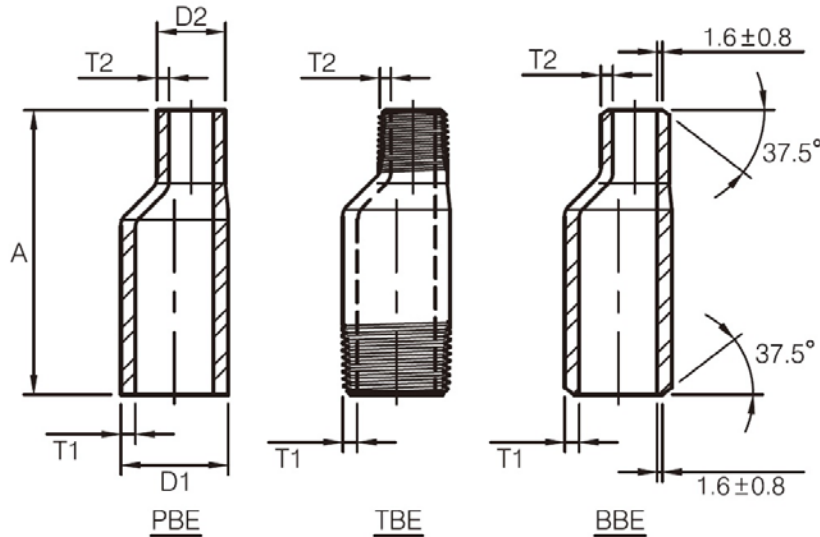

Nom. Pipe Size	Outside Diameter		Wall Thickness								
	Large End D1	Small End D2	T1				T2				
			End To End "A"	Sch40 (STD)	Sch80 (XS)	Sch160	XXS	Sch40 (STD)	Sch80 (XS)	Sch160	XXS
4"x3/8"	114.3	17.1	229	6.0	8.6	13.5	17.1	2.3	3.2	-	-
4"x1/2"	114.3	21.3	229	6.0	8.6	13.5	17.1	2.8	3.7	4.8	7.5
4"x3/4"	114.3	26.7	229	6.0	8.6	13.5	17.1	2.9	3.9	5.6	7.8
4"x1"	114.3	33.4	229	6.0	8.6	13.5	17.1	3.4	4.5	6.4	9.1
4"x1-1/4"	114.3	42.2	229	6.0	8.6	13.5	17.1	3.6	4.9	6.4	9.7
4"x1-1/2"	114.3	48.3	229	6.0	8.6	13.5	17.1	3.7	5.1	7.1	10.2
4"x2"	114.3	60.3	229	6.0	8.6	13.5	17.1	3.9	5.5	8.7	11.1
4"x2-1/2"	114.3	73.0	229	6.0	8.6	13.5	17.1	5.2	7.0	9.5	14.0
4"x3"	114.3	88.9	229	6.0	8.6	13.5	17.1	5.5	7.6	11.1	15.2
4"x3-1/2"	114.3	101.6	229	6.0	8.6	13.5	17.1	5.7	8.1	-	-

- (1) Dimensions in accordance with MSS SP-95-2014.
- (2) Wall Thickness (T1 & T2) in accordance with ASME B36.10M.
- (3) Connection end types:
  - PBE : Plain Both Ends
  - PSE : Plain Small End
  - PLE : Plain Large End
  - BBE : Bevel Both Ends
  - BSE : Bevel Small End
  - BLE : Bevel Large End

- TBE : Thread Both Ends
- TSE : Thread Small End
- TLE : Thread Large End

## Threaded Union

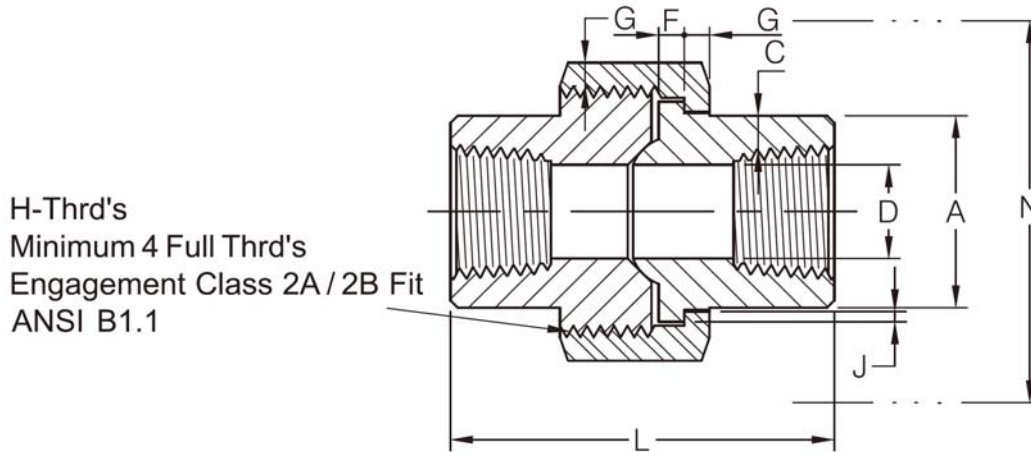

### 3000Lb

Nom. Pipe Size	Pipe End (Min) A	Wall (Min) C	Water Way Bore D <sup>(1)</sup>	Male Flange (Min) F	Nut (Min) G	Threads Per 25.4mm H	Bearing (Min) J	Length Assem. Nom. L	Clear Assem. Nut N
1/8"	14.7	2.41	8.43 6.43	3.18	3.18	16	1.24	41.4	50.8
1/4"	19.0	3.02	11.13 9.45	3.18	3.18	16	1.24	41.4	50.8
3/8"	22.9	3.20	14.27 13.51	3.43	3.43	14	1.37	46.0	55.9
1/2"	27.7	3.73	17.86 17.07	3.68	3.68	14	1.50	49.0	58.4
3/4"	33.5	3.91	23.01 21.39	4.06	4.06	11	1.68	56.9	66.0
1"	41.4	4.55	28.98 27.74	4.57	4.45	11	1.85	62.0	78.7
1-1/4"	50.5	4.85	37.69 35.36	5.33	5.21	11	2.13	71.1	94.0
1-1/2"	57.2	5.08	43.54 41.20	5.84	5.59	10	2.31	76.5	111.8
2"	70.1	5.54	55.58 52.12	6.60	6.35	10	2.69	86.1	132.1
2-1/2"	85.3	7.01	66.27 64.31	7.49	7.11	8	3.07	102.4	149.9
3"	102.4	7.62	88.25 77.27	8.26	8.00	8	3.53	109.0	175.3

- (1) Upper and lower values for each size are the respective maximum and minimum dimensions.  
 (2) Dimensions in accordance with MSS SP-83-2014.

## Threaded Union

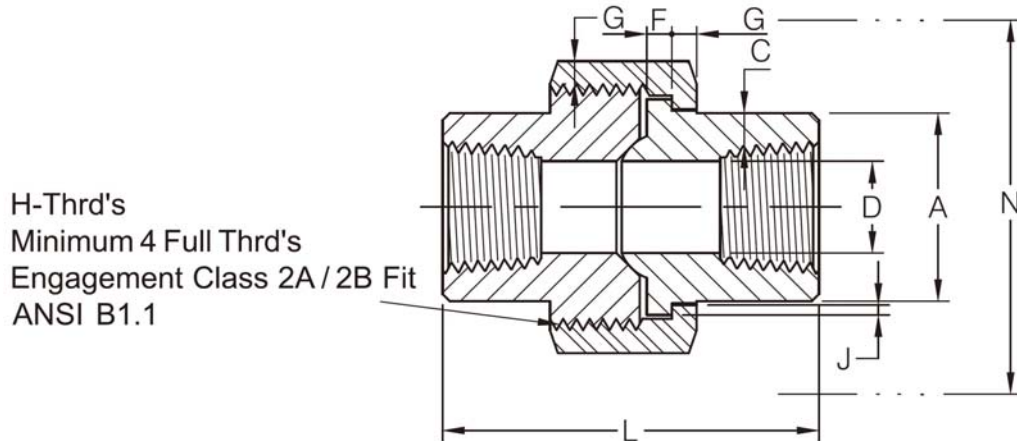

### 6000Lb

Nom. Pipe Size	Pipe End (Min) A	Wall (Min) C	Water Way Bore D <sup>(1)</sup>	Male Flange (Min) F	Nut (Min) G	Threads Per 25.4mm H	Bearing (Min) J	Length Assem. Nom. L	Clear Assem. Nut N
1/8"	16.5	3.15	8.43 3.20	3.18	3.18	16	1.24	41.4	50.8
1/4"	21.1	3.68	11.13 5.59	3.43	3.43	14	1.37	46.0	55.9
3/8"	25.1	4.01	14.27 8.36	3.68	3.68	14	1.50	49.0	58.4
1/2"	31.0	4.78	17.86 11.02	4.06	4.06	11	1.68	56.9	66.0
3/4"	37.8	5.56	23.01 14.78	4.57	4.45	11	1.85	62.0	78.7
1"	46.2	6.35	28.98 19.94	5.33	5.21	10	2.13	71.1	94.0
1-1/4"	54.9	6.35	37.69 28.70	5.84	5.59	10	2.31	76.5	111.8
1-1/2"	62.5	7.14	43.54 33.22	6.60	6.35	10	2.69	86.1	132.1
2"	77.7	8.74	55.58 42.09	7.49	7.11	8	3.07	102.4	149.9
2-1/2"	92.2	9.53	66.27 53.21	8.26	8.00	8	3.53	109.0	175.3
3"	111.3	11.13	82.55 65.89	10.19	10.19	8	4.06	158 <sup>(2)</sup>	200.7

(1) Upper and lower values for each size are the respective maximum and minimum dimensions.

(2) This length 158mm is by our standard and the length as per MSS SP-83-2014 is 190.5mm.

(3) Dimensions in accordance with MSS SP-83-2014.

## Union Male x Female Threaded

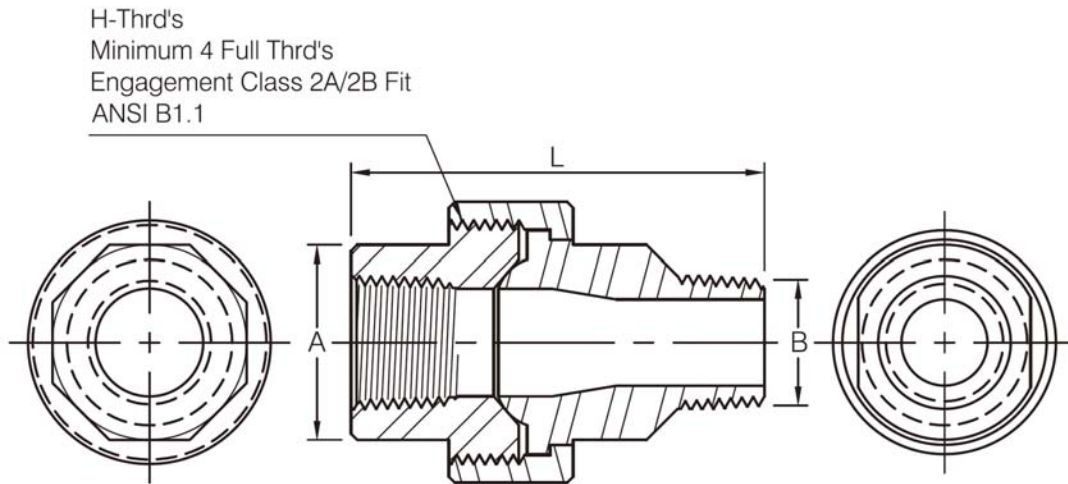

### 3000Lb

Nom. Pipe Size	A <sup>(1)</sup> (Min)	B	L
1/4"	19.0	13.7	55.4
3/8"	22.9	17.1	60.0
1/2"	27.7	21.3	68.0
3/4"	33.5	26.7	75.9
1"	41.4	33.4	86.0
1-1/4"	50.5	42.2	95.1
1-1/2"	57.2	48.3	100.5
2"	70.1	60.3	112.1

(1) Dimensions refer to MSS SP-83 TABLE 5.

## Union Male Threaded x SW

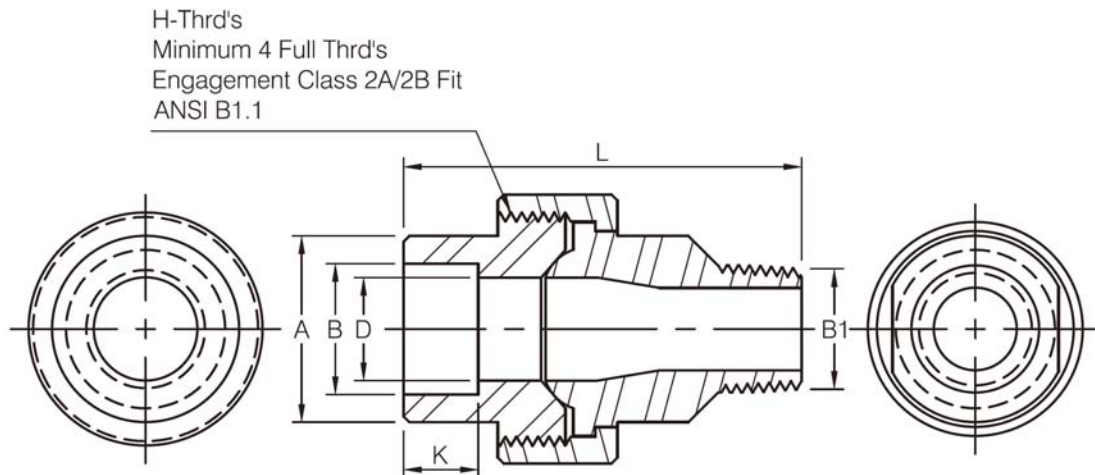

### 3000Lb

Nom. Pipe Size	A <sup>(1)</sup> (Min)	B1	B	D	K (Min)	L
1/4"	21.8	13.7	14.61 14.10	10.01 8.48	9.7	55.4
3/8"	25.9	17.1	18.03 17.53	13.28 11.76	9.7	60.0
1/2"	31.2	21.3	22.23 21.72	16.56 15.04	9.7	68.0
3/4"	37.1	26.7	27.56 27.05	21.69 20.17	12.7	75.9
1"	45.5	33.4	34.29 33.78	27.41 25.88	12.7	86.0
1-1/4"	54.9	42.2	43.05 42.55	35.81 34.29	12.7	95.1
1-1/2"	61.5	48.3	49.15 48.64	41.66 40.13	12.7	100.5
2"	75.2	60.3	61.62 61.11	53.26 51.74	15.7	112.1

(1) Dimensions refer to MSS SP-83 TABLE 5.

## Threaded Adapter

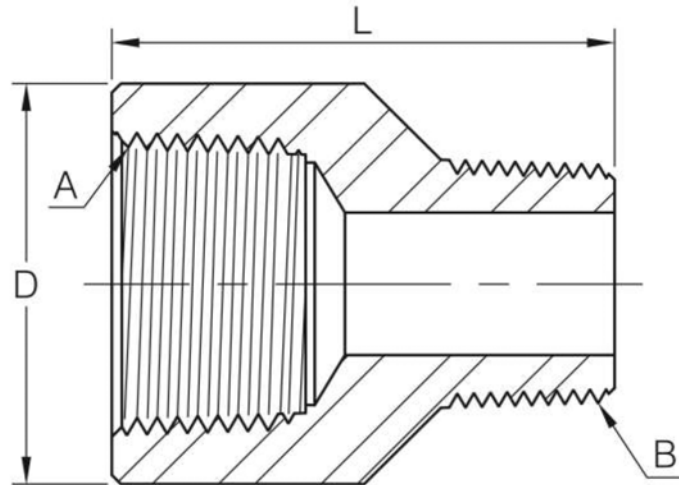

### 3000Lb

DN	Nom Pipe Size A	D	L	Threaded Size B
8	1/4"	19	33	1/8"
10	3/8"	22	35	1/4"
15	1/2"	28	42	3/8"
20	3/4"	35	47	1/2"
25	1"	44	55	3/4"
32	1-1/4"	57	63	1"
40	1-1/2"	64	66	1-1/4"
50	2"	76	76	1-1/2"
65	2-1/2"	92	90	2"
80	3"	108	110	2-1/2"
100	4"	140	120	3"



## Threaded 90° Branch Outlet

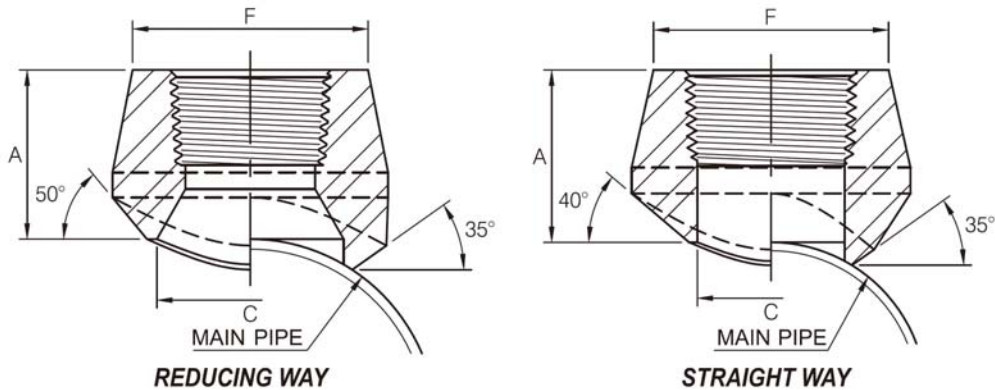

OutLet Pipe NPS	Reducing Way					
	A		C		F	
	3000Lb	6000Lb	3000Lb	6000Lb	3000Lb	6000Lb
1/8"	19.0	-	13.7	-	17.3	-
1/4"	19.0	-	13.7	-	22.0	-
3/8"	20.6	-	17.1	-	25.9	-
1/2"	25.4	31.8	21.3	16.6	31.4	33.9
3/4"	26.9	36.6	26.7	21.2	37.1	41.2
1"	33.3	39.6	33.4	27.0	45.5	49.9
1-1/4"	33.3	41.1	42.2	35.8	57.0	58.6
1-1/2"	35.0	42.3	48.3	41.2	64.0	66.7
2"	38.1	52.3	60.3	51.6	76.0	83.2
2-1/2"	46.0	-	73.0	-	92.0	-
3"	50.8	-	88.9	-	109.2	-
4"	57.2	-	114.3	-	140.0	-

OutLet Pipe NPS	Straight Way		
	A	C	F
	3000Lb		
1/8"	-	-	-
1/4"	19.0	11.5	22.0
3/8"	21.0	14.5	25.9
1/2"	25.4	16.5	31.4
3/4"	26.9	21.5	37.1
1"	33.3	27.2	45.5
1-1/4"	33.3	36.0	57.0
1-1/2"	35.0	42.0	64.0
2"	38.1	53.0	76.0
2-1/2"	46.0	65.0	92.0
3"	50.8	80.0	109.2
4"	57.2	104.0	140.0

- (1) 3000LBS outlet size 4 and less fit a number of run pipe sizes and the fittings are marked accordingly.
- (2) Dimensions in accordance with MSS SP-97-2012.

### Conventional Run Size Combinations

		OUTLET SIZE										
		1/4"	3/8"	1/2"	3/4"	1"	1-1/4"	1-1/2"	2"	2-1/2"	3"	4"
RUN SIZE (Main Pipe)	Reducing way	3/8"~3/4" 1"~36"	1/2" 3/4"~1-1/4" 1-1/2"~36"	3/4" 1" 1-1/4" 1-1/2"~3" 3-1/2"~36"	1" 1-1/4" 1-1/2" 2"~3" 3-1/2"~6" 8"~36"	1-1/4" 1-1/2" 2" 2-1/2" 3" 3-1/2"~4" 5"~10" 12~36"	1-1/2" 2" 2-1/2" 3" 3-1/2"~5" 6"~8" 10"~36"	2" 2-1/2" 3" 3-1/2" 4"~5" 5"~6" 6"~10" 12"~36"	2-1/2" 3" 3-1/2" 4" 5"~6" 8"~10" 12"~18" 20"~36"	3" 3-1/2" 4" 5" 6" 8" 10"~14" 16"~36"	3-1/2" 4" 5" 6" 8" 10" 12"~16" 18"~36"	5" 6" 8" 10" 12"~14" 16"~18" 20"~24" 26"~36"
	Straight way	3/8"~36"	1/2"~36"	3/4"~36"	1"~36"	1-1/4"~1-1/2" 2"~36"	1-1/2" 2"~3" 3-1/2"~36"	2" 2-1/2"~4" 5"~36"	2-1/2" 3"~3-1/2" 4"~6" 8"~36"	3" 3-1/2"~4" 5"~8" 10"~36"	3-1/2" 4" 5" 6" 8"~12" 14"~36"	5" 6" 8" 10" 12"~16" 18"~36"

Each charted outlet size is designed to fit a number of run pipe size.

**Threaded 45° Branch Outlet**

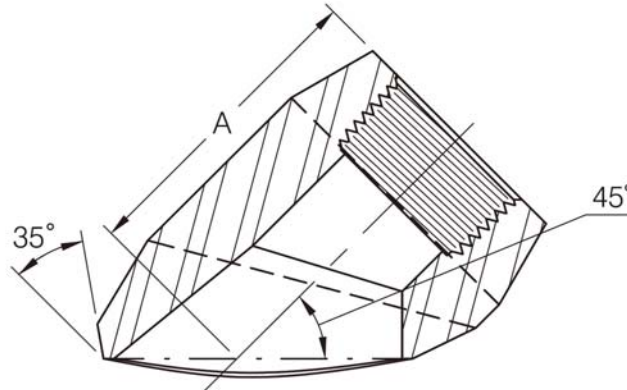

Outlet Pipe		A			
DN	Inch	3000Lb		6000Lb	
		Min	Max	Min	Max
8	1/4"	38.1	42.9	38.9	47.6
10	3/8"	38.1	42.9	38.9	47.6
15	1/2"	38.1	44.5	46.0	55.6
20	3/4"	46.0	50.8	54.0	63.5
25	1"	54.0	63.5	61.1	73.0
32	1-1/4"	61.1	76.2	65.1	77.8
40	1-1/2"	63.5	76.2	78.6	85.7
50	2"	76.2	84.1	78.6	104.8

(1) Dimensions in accordance with MSS SP-97-2012.

## Threaded 90° Elbow Outlet

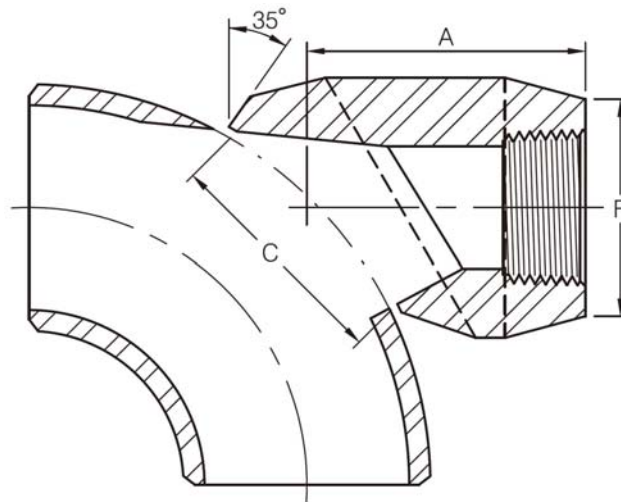

Outlet Pipe		A		C		F	
DN	Inch	3000Lb	6000Lb	3000Lb	6000Lb	3000Lb	6000Lb
8	1/4"	40.5	40.5	35.2	34.9	22.0	26.0
10	3/8"	40.5	40.5	35.2	34.9	25.9	33.0
15	1/2"	40.5	47.6	35.2	34.9	31.4	38.0
20	3/4"	47.6	55.6	43.6	43.6	37.1	44.0
25	1"	55.6	60.3	54.0	54.0	45.5	57.0
32	1-1/4"	60.3	66.7	67.5	67.5	57.0	64.0
40	1-1/2"	66.7	85.7	76.2	76.2	64.0	76.0
50	2"	81.0	-	104.8	-	76.0	-
65	2-1/2"	82.6	-	106.4	-	92.0	-
80	3"	96.8	-	125.4	-	109.2	-
100	4"	114.3	-	163.5	-	140.0	-

**Nipple Branch Outlet Threaded**

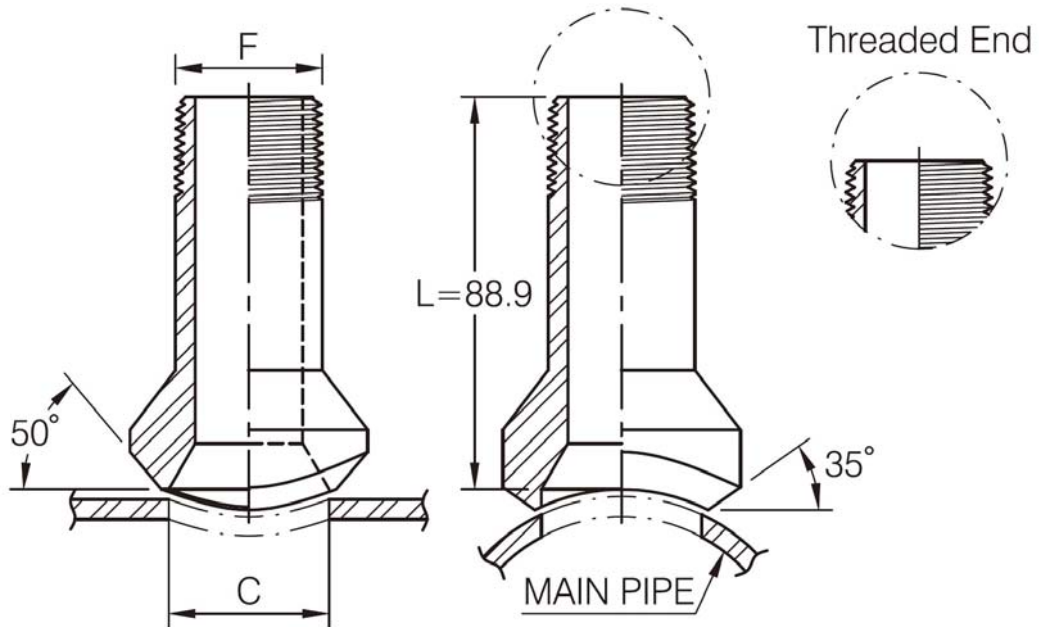

Outlet Pipe	C		F
	3000Lb	6000Lb	
1/2"	23.8	13.8	21.3
3/4"	30.2	18.9	26.7
1"	36.5	24.3	33.4
1-1/4"	44.5	32.5	42.2
1-1/2"	50.8	38.1	48.3
2"	65.1	49.2	60.3

## 90° Elbow Socket Weld

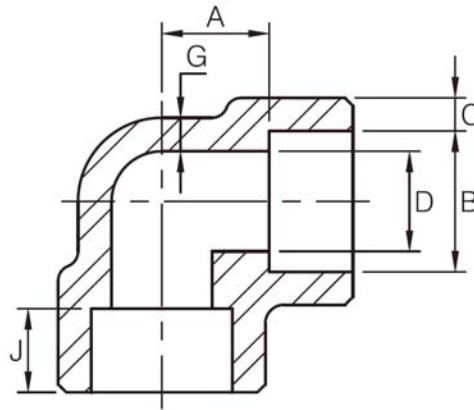

DN	Nom Pipe Size	A			B	D			C <sup>(1)</sup>						G (Min)			J (Min)
		3M	6M	9M		3M	6M	9M	3M		6M		9M		3M	6M	9M	
									Avg	Min	Avg	Min	Avg	Min				
6	1/8"	11.0	11.0	-	10.8	6.9	4.0	-	3.18	3.18	3.96	3.43	-	-	2.41	3.15	-	9.5
8	1/4"	11.0	13.5	-	14.2	9.3	6.4	-	3.78	3.30	4.60	4.01	-	-	3.02	3.68	-	9.5
10	3/8"	13.5	15.5	-	17.6	12.6	9.2	-	4.01	3.50	5.03	4.37	-	-	3.20	4.01	-	9.5
15	1/2"	15.5	19.0	25.5	21.8	15.8	11.8	6.4	4.67	4.09	5.97	5.18	9.35	8.18	3.73	4.78	7.47	9.5
20	3/4"	19.0	22.5	28.5	27.2	21.0	15.6	11.1	4.90	4.27	6.96	6.04	9.78	8.56	3.91	5.56	7.82	12.5
25	1"	22.5	27.0	32.0	33.9	26.7	20.7	15.2	5.69	4.98	7.92	6.93	11.38	9.96	4.55	6.35	9.09	12.5
32	1-1/4"	27.0	32.0	35.0	42.7	35.1	29.5	22.8	6.07	5.28	7.92	6.93	12.14	10.62	4.85	6.35	9.70	12.5
40	1-1/2"	32.0	38.0	38.0	48.8	40.9	34.0	28.0	6.35	5.54	8.92	7.80	12.70	11.12	5.08	7.14	10.15	12.5
50	2"	38.0	41.0	54.0	61.2	52.5	42.9	38.2	6.93	6.04	10.92	9.50	13.84	12.12	5.54	8.74	11.07	16.0
65	2-1/2"	41.0	-	-	73.9	62.7	-	-	8.76	7.67	-	-	-	-	7.01	-	-	16.0
80	3"	57.0	-	-	89.8	78.0	-	-	9.52	8.30	-	-	-	-	7.62	-	-	16.0
100	4"	66.5	-	-	115.2	102.3	-	-	10.69	9.35	-	-	-	-	8.56	-	-	19.0

- (1) Average of socket wall thickness around periphery shall be no less than listed values. The minimum values are permitted in localized areas.
- (2) 3M, 6M and 9M denote 3000Lb, 6000Lb and 9000Lb.
- (3) Dimensions in accordance with ASME B16.11-2011.

## 45° Elbow Socket Weld

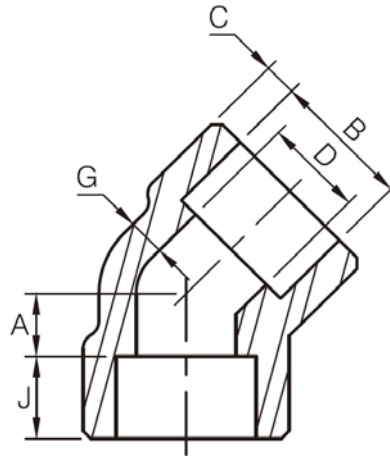

DN	Nom. Pipe Size	A			B	D			C <sup>(1)</sup>						G (Min)			J (Min)
		3M	6M	9M		3M	6M	9M	3M		6M		9M		3M	6M	9M	
									Avg	Min	Avg	Min	Avg	Min				
6	1/8"	8.0	8.0	-	10.8	6.9	4.0	-	3.18	3.18	3.96	3.43	-	-	2.41	3.15	-	9.5
8	1/4"	8.0	8.0	-	14.2	9.3	6.4	-	3.78	3.30	4.60	4.01	-	-	3.02	3.68	-	9.5
10	3/8"	8.0	11.0	-	17.6	12.6	9.2	-	4.01	3.50	5.03	4.37	-	-	3.20	4.01	-	9.5
15	1/2"	11.0	12.5	15.5	21.8	15.8	11.8	6.4	4.67	4.09	5.97	5.18	9.35	8.18	3.73	4.78	7.47	9.5
20	3/4"	13.0	14.0	19.0	27.2	21.0	15.6	11.1	4.90	4.27	6.96	6.04	9.78	8.56	3.91	5.56	7.82	12.5
25	1"	14.0	17.5	20.5	33.9	26.7	20.7	15.2	5.69	4.98	7.92	6.93	11.38	9.96	4.55	6.35	9.09	12.5
32	1-1/4"	17.5	20.5	22.5	42.7	35.1	29.5	22.8	6.07	5.28	7.92	6.93	12.14	10.62	4.85	6.35	9.70	12.5
40	1-1/2"	20.5	25.5	25.5	48.8	40.9	34.0	28.0	6.35	5.54	8.92	7.80	12.70	11.12	5.08	7.14	10.15	12.5
50	2"	25.5	28.5	28.5	61.2	52.5	42.9	38.2	6.93	6.04	10.92	9.50	13.84	12.12	5.54	8.74	11.07	16.0
65	2-1/2"	28.5	-	-	73.9	62.7	-	-	8.76	7.67	-	-	-	-	7.01	-	-	16.0
80	3"	32.0	-	-	89.8	78.0	-	-	9.52	8.30	-	-	-	-	7.62	-	-	16.0
100	4"	41.0	-	-	115.2	102.3	-	-	10.69	9.35	-	-	-	-	8.56	-	-	19.0

- (1) Average of socket wall thickness around periphery shall be no less than listed values. The minimum values are permitted in localized areas.
- (2) 3M, 6M and 9M denote 3000Lb, 6000Lb and 9000Lb.
- (3) Dimensions in accordance with ASME B16.11-2011.

## Tee Socket Weld

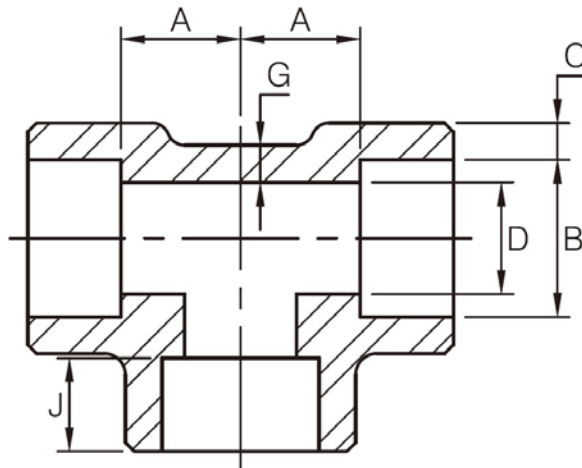

DN	Nom Pipe Size	A			B	D			C <sup>(1)</sup>						G (Min)			J (Min)
		3M	6M	9M		3M	6M	9M	3M		6M		9M		3M	6M	9M	
									Avg	Min	Avg	Min	Avg	Min				
6	1/8"	11.0	11.0	-	10.8	6.9	4.0	-	3.18	3.18	3.96	3.43	-	-	2.41	3.15	-	9.5
8	1/4"	11.0	13.5	-	14.2	9.3	6.4	-	3.78	3.30	4.60	4.01	-	-	3.02	3.68	-	9.5
10	3/8"	13.5	15.5	-	17.6	12.6	9.2	-	4.01	3.50	5.03	4.37	-	-	3.20	4.01	-	9.5
15	1/2"	15.5	19.0	25.5	21.8	15.8	11.8	6.4	4.67	4.09	5.97	5.18	9.35	8.18	3.73	4.78	7.47	9.5
20	3/4"	19.0	22.5	28.5	27.2	21.0	15.6	11.1	4.90	4.27	6.96	6.04	9.78	8.56	3.91	5.56	7.82	12.5
25	1"	22.5	27.0	32.0	33.9	26.7	20.7	15.2	5.69	4.98	7.92	6.93	11.38	9.96	4.55	6.35	9.09	12.5
32	1-1/4"	27.0	32.0	35.0	42.7	35.1	29.5	22.8	6.07	5.28	7.92	6.93	12.14	10.62	4.85	6.35	9.70	12.5
40	1-1/2"	32.0	38.0	38.0	48.8	40.9	34.0	28.0	6.35	5.54	8.92	7.80	12.70	11.12	5.08	7.14	10.15	12.5
50	2"	38.0	41.0	54.0	61.2	52.5	42.9	38.2	6.93	6.04	10.92	9.50	13.84	12.12	5.54	8.74	11.07	16.0
65	2-1/2"	41.0	-	-	73.9	62.7	-	-	8.76	7.67	-	-	-	-	7.01	-	-	16.0
80	3"	57.0	-	-	89.8	78.0	-	-	9.52	8.30	-	-	-	-	7.62	-	-	16.0
100	4"	66.5	-	-	115.2	102.3	-	-	10.69	9.35	-	-	-	-	8.56	-	-	19.0

- (1) Average of socket wall thickness around periphery shall be no less than listed values. The minimum values are permitted in localized areas.
- (2) 3M, 6M and 9M denote 3000Lb, 6000Lb and 9000Lb.
- (3) Dimensions in accordance with ASME B16.11-2011.

## 45° Lateral Tee Socket Weld

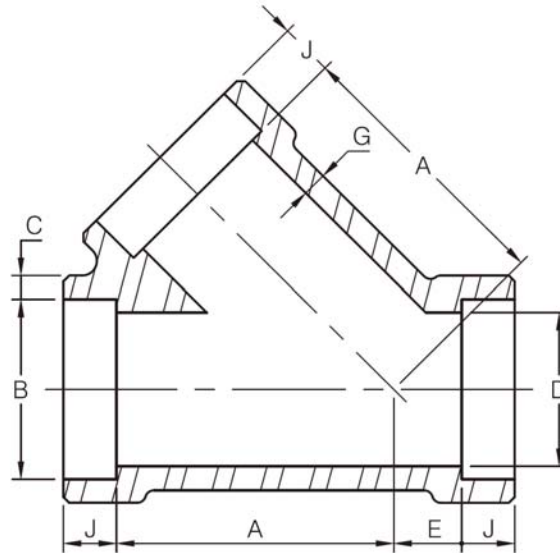

DN	Nom. Pipe Size	B	C <sup>(1)</sup>				D <sup>(1)</sup>		A		E		G <sup>(1)</sup> (Min)		J <sup>(1)</sup> (Min)
			3M		6M		3M	6M	3M	6M	3M	6M	3M	6M	
			Avg	Min	Avg	Min									
15	1/2"	21.8	4.67	5.97	4.09	5.18	15.8	11.8	35	41	9	9	3.75	4.78	9.5
20	3/4"	27.2	4.90	6.96	4.27	6.04	21.0	15.6	41	51	9	12	3.95	5.56	12.5
25	1"	33.9	5.69	7.92	4.98	6.93	26.7	20.7	51	59	12	17	4.55	6.35	12.5
32	1-1/4"	42.7	6.07	7.92	5.28	6.93	35.1	29.5	59	68	17	21	4.85	6.35	12.5
40	1-1/2"	48.8	6.35	8.92	5.54	7.80	40.9	34.0	68	95	21	24	5.10	7.14	12.5
50	2"	61.2	6.93	10.92	6.04	9.50	52.5	42.9	95	106	24	31	5.55	8.74	16.0
65	2-1/2"	73.9	8.76	-	7.67	-	62.7	-	118	-	38	-	7.05	-	16.0

(1) Dimensions refer to ASME B16.11 for class 3M, socket weld fittings.



## Cross Socket Weld

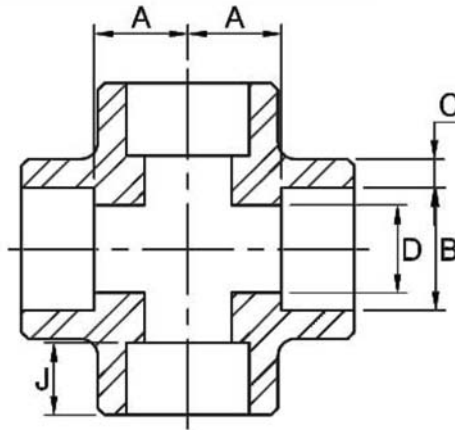

DN	Nom Pipe Size	A			B	D			C <sup>(1)</sup>						G (Min)			J (Min)
		3M	6M	9M		3M	6M	9M	3M		6M		9M		3M	6M	9M	
									Avg	Min	Avg	Min	Avg	Min				
6	1/8"	11.0	11.0	-	10.8	6.9	4.0	-	3.18	3.18	3.96	3.43	-	-	2.41	3.15	-	9.5
8	1/4"	11.0	13.5	-	14.2	9.3	6.4	-	3.78	3.30	4.60	4.01	-	-	3.02	3.68	-	9.5
10	3/8"	13.5	15.5	-	17.6	12.6	9.2	-	4.01	3.50	5.03	4.37	-	-	3.20	4.01	-	9.5
15	1/2"	15.5	19.0	25.5	21.8	15.8	11.8	6.4	4.67	4.09	5.97	5.18	9.35	8.18	3.73	4.78	7.47	9.5
20	3/4"	19.0	22.5	28.5	27.2	21.0	15.6	11.1	4.90	4.27	6.96	6.04	9.78	8.56	3.91	5.56	7.82	12.5
25	1"	22.5	27.0	32.0	33.9	26.7	20.7	15.2	5.69	4.98	7.92	6.93	11.38	9.96	4.55	6.35	9.09	12.5
32	1-1/4"	27.0	32.0	35.0	42.7	35.1	29.5	22.8	6.07	5.28	7.92	6.93	12.14	10.62	4.85	6.35	9.70	12.5
40	1-1/2"	32.0	38.0	38.0	48.8	40.9	34.0	28.0	6.35	5.54	8.92	7.80	12.70	11.12	5.08	7.14	10.15	12.5
50	2"	38.0	41.0	54.0	61.2	52.5	42.9	38.2	6.93	6.04	10.92	9.50	13.84	12.12	5.54	8.74	11.07	16.0
65	2-1/2"	41.0	-	-	73.9	62.7	-	-	8.76	7.67	-	-	-	-	7.01	-	-	16.0
80	3"	57.0	-	-	89.8	78.0	-	-	9.52	8.30	-	-	-	-	7.62	-	-	16.0
100	4"	66.5	-	-	115.2	102.3	-	-	10.69	9.35	-	-	-	-	8.56	-	-	19.0

- (1) Average of socket wall thickness around periphery shall be no less than listed values. The minimum values are permitted in localized areas.
- (2) 3M, 6M and 9M denote 3000Lb, 6000Lb and 9000Lb.
- (3) Dimensions in accordance with ASME B16.11-2011.

## Full Coupling Socket Weld

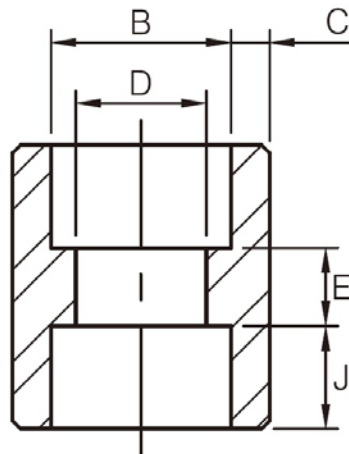

DN	Nom. Pipe Size	Socket Bore Dia. B	Bore Dia. Of Fitting D			Socket Wall Thickness C <sup>(1)</sup>						Laying Length E	Depth of Socket (Min) J
						3M		6M		9M			
			3M	6M	9M	Avg	Min	Avg	Min	Avg	Min		
6	1/8"	10.8	6.9	4.0	-	3.18	3.18	3.96	3.43	-	-	6.5	9.5
8	1/4"	14.2	9.3	6.4	-	3.78	3.30	4.60	4.01	-	-	6.5	9.5
10	3/8"	17.6	12.6	9.2	-	4.01	3.50	5.03	4.37	-	-	6.5	9.5
15	1/2"	21.8	15.8	11.8	6.4	4.67	4.09	5.97	5.18	9.35	8.18	9.5	9.5
20	3/4"	27.2	21.0	15.6	11.1	4.90	4.27	6.96	6.04	9.78	8.56	9.5	12.5
25	1"	33.9	26.7	20.7	15.2	5.69	4.98	7.92	6.93	11.38	9.96	12.5	12.5
32	1-1/4"	42.7	35.1	29.5	22.8	6.07	5.28	7.92	6.93	12.14	10.62	12.5	12.5
40	1-1/2"	48.8	40.9	34.0	28.0	6.35	5.54	8.92	7.80	12.70	11.12	12.5	12.5
50	2"	61.2	52.5	42.9	38.2	6.93	6.04	10.92	9.50	13.84	12.12	19.0	16.0
65	2-1/2"	73.9	62.7	-	-	8.76	7.67	-	-	-	-	19.0	16.0
80	3"	89.8	78.0	-	-	9.52	8.30	-	-	-	-	19.0	16.0
100	4"	115.2	102.3	-	-	10.69	9.35	-	-	-	-	19.0	19.0

(1) Average of socket wall thickness around periphery shall be no less than listed values. The minimum values are permitted in localized areas.

(2) 3M, 6M and 9M denote 3000Lb, 6000Lb and 9000Lb.

(3) Dimensions in accordance with ASME B16.11-2011.

Half Coupling Socket Weld

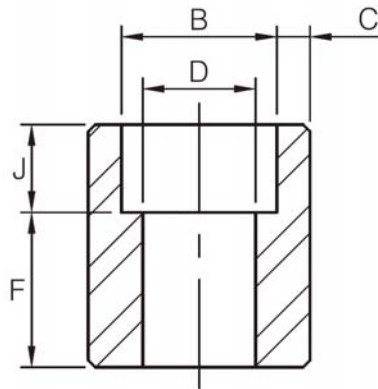

DN	Nom. Pipe Size	Socket Bore Dia. B	Bore Dia. Of Fitting D			Socket Wall Thickness C <sup>(1)</sup>						Laying Length F	Depth of Socket (Min) J
						3M		6M		9M			
			3M	6M	9M	Avg	Min	Avg	Min	Avg	Min		
6	1/8"	10.8	6.9	4.0	-	3.18	3.18	3.96	3.43	-	-	16.0	9.5
8	1/4"	14.2	9.3	6.4	-	3.78	3.30	4.60	4.01	-	-	16.0	9.5
10	3/8"	17.6	12.6	9.2	-	4.01	3.50	5.03	4.37	-	-	17.5	9.5
15	1/2"	21.8	15.8	11.8	6.4	4.67	4.09	5.97	5.18	9.35	8.18	22.5	9.5
20	3/4"	27.2	21.0	15.6	11.1	4.90	4.27	6.96	6.04	9.78	8.56	24.0	12.5
25	1"	33.9	26.7	20.7	15.2	5.69	4.98	7.92	6.93	11.38	9.96	28.5	12.5
32	1-1/4"	42.7	35.1	29.5	22.8	6.07	5.28	7.92	6.93	12.14	10.62	30.0	12.5
40	1-1/2"	48.8	40.9	34.0	28.0	6.35	5.54	8.92	7.80	12.70	11.12	32.0	12.5
50	2"	61.2	52.5	42.9	38.2	6.93	6.04	10.92	9.50	13.84	12.12	41.0	16.0
65	2-1/2"	73.9	62.7	-	-	8.76	7.67	-	-	-	-	43.0	16.0
80	3"	89.8	78.0	-	-	9.52	8.30	-	-	-	-	44.5	16.0
100	4"	115.2	102.3	-	-	10.69	9.35	-	-	-	-	48.0	19.0

- (1) Average of socket wall thickness around periphery shall be no less than listed values. The minimum values are permitted in localized areas.
- (2) 3M, 6M and 9M denote 3000Lb, 6000Lb and 9000Lb.
- (3) Reducer: "C, J, E" in accordance with large size, "D" in accordance with small size and the others in accordance with each size.
- (4) Dimensions in accordance with ASME B16.11-2011.

## Reducing Coupling Socket Weld

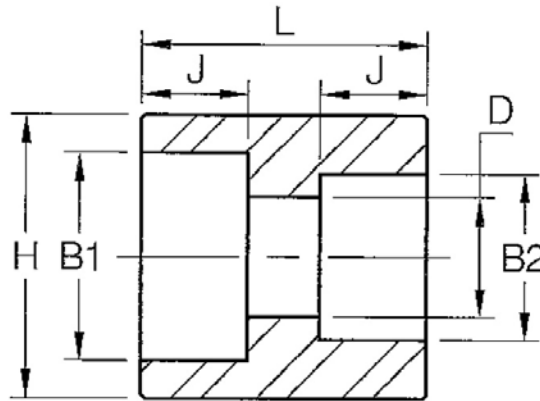

Nom. Pipe Size	H		B1	B2	D		J		L	
	3M	6M			3M	6M	3M	6M	3M	6M
1/4"x1/8"	22.2	23.8	14.3	10.9	6.9	4.0	10.5	10.5	27.5	27.5
3/8"x1/8"	26.1	28.1	17.7	10.9	6.9	4.0	10.5	10.5	28.5	28.5
3/8"x1/4"	26.1	28.1	17.7	14.3	9.3	6.4	10.5	10.5	28.5	28.5
1/2"x1/8"	31.6	34.2	21.9	10.9	6.9	4.0	12.5	12.5	34.5	34.5
1/2"x1/4"	31.6	34.2	21.9	13.3	9.3	6.4	12.5	12.5	34.5	34.5
1/2"x3/8"	31.6	34.2	21.9	17.7	12.6	9.2	12.5	12.5	34.5	34.5
3/4"x1/8"	37.4	41.6	27.3	10.9	6.9	4.0	14.0	14.0	37.5	37.5
3/4"x1/4"	37.4	41.6	27.3	14.3	9.3	6.4	14.0	14.0	37.5	37.5
3/4"x3/8"	37.4	41.6	27.3	17.7	12.6	9.2	14.0	14.0	37.5	37.5
3/4"x1/2"	37.4	41.6	27.3	21.9	15.8	11.8	14.0	14.0	37.5	37.5
1"x1/8"	45.7	50.2	34.0	10.9	6.9	4.0	15.0	15.0	43.0	43.0
1x1/4"	45.7	50.2	34.0	14.3	9.3	6.4	15.0	15.0	43.0	43.0
1"x3/8"	45.7	50.2	34.0	17.7	12.6	9.2	15.0	15.0	43.0	43.0
1"x1/2"	45.7	50.2	34.0	21.9	15.8	11.8	15.0	15.0	43.0	43.0
1"x3/4"	45.7	50.2	34.0	27.3	21.0	15.6	15.0	15.0	43.0	43.0
1-1/4"x1/8"	55.3	59.0	42.8	10.9	6.9	4.0	17.0	17.0	47.0	47.0
1-1/4"x1/4"	55.3	59.0	42.8	14.3	9.3	6.4	17.0	17.0	47.0	47.0
1-1/4"x3/8"	55.3	59.0	42.8	17.7	12.6	9.2	17.0	17.0	47.0	47.0
1-1/4"x1/2"	55.3	59.0	42.8	21.9	15.8	11.8	17.0	17.0	47.0	47.0
1-1/4"x3/4"	55.3	59.0	42.8	27.3	21.0	15.6	17.0	17.0	47.0	47.0
1-1/4"x1"	55.3	59.0	42.8	34.0	26.7	20.7	17.0	17.0	47.0	47.0
1-1/2"x1/8"	62.5	67.1	48.9	10.9	6.9	4.0	17.5	17.5	48.0	48.0
1-1/2"x1/4"	62.5	67.1	48.9	14.3	9.3	6.4	17.5	17.5	48.0	48.0
1-1/2"x3/8"	62.5	67.1	48.9	17.7	12.6	9.2	17.5	17.5	48.0	48.0
1-1/2"x1/2"	62.5	67.1	48.9	21.9	15.8	11.8	17.5	17.5	48.0	48.0
1-1/2"x3/4"	62.5	67.1	48.9	27.3	21.0	15.6	17.5	17.5	48.0	48.0
1-1/2"x1"	62.5	67.1	48.9	34.0	26.7	20.7	17.5	17.5	48.0	48.0
1-1/2"x1-1/4"	62.5	67.1	48.9	42.8	35.1	29.5	17.5	17.5	48.0	48.0
2"x1/8"	75.6	83.6	61.4	10.9	6.9	4.0	22.0	22.0	63.0	63.0
2"x1/4"	75.6	83.6	61.4	14.3	9.3	6.4	22.0	22.0	63.0	63.0
2"x3/8"	75.6	83.6	61.4	17.7	12.6	9.2	22.0	22.0	63.0	63.0
2"x1/2"	75.6	83.6	61.4	21.9	15.8	11.8	22.0	22.0	63.0	63.0
2"x3/4"	75.6	83.6	61.4	27.3	21.0	15.6	22.0	22.0	63.0	63.0
2"x1"	75.6	83.6	61.4	34.0	26.7	20.7	22.0	22.0	63.0	63.0
2"x1-1/4"	75.6	83.6	61.4	42.8	35.1	29.5	22.0	22.0	63.0	63.0

## Reducing Coupling Socket Weld

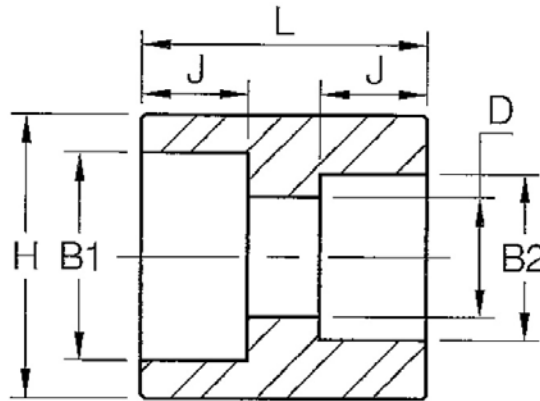

Nom. Pipe Size	H		B1	B2	D		J		L	
	3M	6M			3M	6M	3M	6M	3M	6M
2"x1-1/2"	75.6	83.6	61.4	48.9	40.9	34.0	22.0	22.0	63.0	63.0
2-1/2"x1/8"	92.0	108.5	74.1	10.9	6.9	4.0	22.0	22.4	63.0	63.5
2-1/2"x1/4"	92.0	108.5	74.1	14.3	9.3	6.4	22.0	22.4	63.0	63.5
2-1/2"x3/8"	92.0	108.5	74.1	17.7	12.6	9.2	22.0	22.4	63.0	63.5
2-1/2"x1/2"	92.0	108.5	74.1	21.9	15.8	11.8	22.0	22.4	63.0	63.5
2-1/2"x3/4"	92.0	108.5	74.1	27.3	21.0	15.6	22.0	22.4	63.0	63.5
2-1/2"x1"	92.0	108.5	74.1	34.0	26.7	20.7	22.0	22.4	63.0	63.5
2-1/2"x1-1/4"	92.0	108.5	74.1	42.8	35.1	29.5	22.0	22.4	63.0	63.5
2-1/2"x1-1/2"	92.0	108.5	74.1	48.9	40.9	34.0	22.0	22.4	63.0	63.5
2-1/2"x2"	92.0	108.5	74.1	61.4	52.5	42.9	22.0	22.4	63.0	63.5
3"x1/8"	109.4	127.6	90.0	10.9	6.9	4.0	22.0	25.5	63.0	70.0
3"x1/4"	109.4	127.6	90.0	14.3	9.3	6.4	22.0	25.5	63.0	70.0
3"x3/8"	109.4	127.6	90.0	17.7	12.6	9.2	22.0	25.5	63.0	70.0
3"x1/2"	109.4	127.6	90.0	21.9	15.8	11.8	22.0	25.5	63.0	70.0
3"x3/4"	109.4	127.6	90.0	27.3	21.0	15.6	22.0	25.5	63.0	70.0
3"x1"	109.4	127.6	90.0	34.0	26.7	20.7	22.0	25.5	63.0	70.0
3"x1-1/4"	109.4	127.6	90.0	42.8	35.1	29.5	22.0	25.5	63.0	70.0
3"x1-1/2"	109.4	127.6	90.0	48.9	40.9	34.0	22.0	25.5	63.0	70.0
3"x2"	109.4	127.6	90.0	61.4	52.5	42.9	22.0	25.5	63.0	70.0
3"x2-1/2"	109.4	127.6	90.0	74.1	62.7	53.8	22.0	25.5	63.0	70.0
4"x1/8"	137.1	159.0	115.4	10.9	6.9	4.0	22.0	28.4	63.0	76.2
4"x1/4"	137.1	159.0	115.4	14.3	9.3	6.4	22.0	28.4	63.0	76.2
4"x3/8"	137.1	159.0	115.4	17.7	12.6	9.2	22.0	28.4	63.0	76.2
4"x1/2"	137.1	159.0	115.4	21.9	15.8	11.8	22.0	28.4	63.0	76.2
4"x3/4"	137.1	159.0	115.4	27.3	21.0	15.6	22.0	28.4	63.0	76.2
4"x1"	137.1	159.0	115.4	34.0	26.7	20.7	22.0	28.4	63.0	76.2
4"x1-1/4"	137.1	159.0	115.4	42.8	35.1	29.5	22.0	28.4	63.0	76.2
4"x1-1/2"	137.1	159.0	115.4	48.9	40.9	34.0	22.0	28.4	63.0	76.2
4"x2"	137.1	159.0	115.4	61.4	52.5	42.9	22.0	28.4	63.0	76.2
4"x2-1/2"	137.1	159.0	115.4	74.1	62.7	53.8	22.0	28.4	63.0	76.2
4"x3"	137.1	159.0	115.4	90.0	78.0	66.5	22.0	28.4	63.0	76.2

(1) 3M and 6M denote 3000Lb and 6000Lb.

(2) Dimensions in accordance with ASME B16.11-2011.

**Eccentric Reducer Coupling Socket Weld**

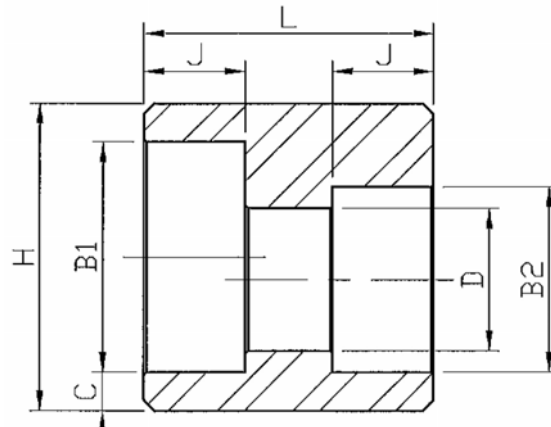

**3000Lb**

Nom. Pipe Size	B1	B2	D	C (Min)	H	J	L
1/4"x1/8"	14.3	10.9	6.9	3.80	22.2	10.5	27.5
3/8"x1/8"	17.7	10.9	6.9	4.05	26.1	10.5	28.5
3/8"x1/4"	17.7	14.3	9.3	4.05	25.1	10.5	28.5
1/2"x1/4"	21.9	14.3	9.3	4.70	31.6	12.5	34.5
1/2"x3/8"	21.9	17.7	12.6	4.70	31.6	12.5	34.5
3/4"x3/8"	27.3	17.7	12.6	4.90	37.4	14.0	37.5
3/4"x1/2"	27.3	21.9	15.8	4.90	37.4	14.0	37.5
1"x3/8"	34.0	17.7	12.6	5.70	45.7	15.0	43.0
1"x1/2"	34.0	21.9	15.8	5.70	45.7	15.0	43.0
1"x3/4"	34.0	27.3	21.0	5.70	45.7	15.0	43.0
1-1/4"x1/2"	42.8	21.9	15.8	6.10	55.3	17.0	47.0
1-1/4"x3/4"	42.8	27.3	21.0	6.10	55.3	17.0	47.0
1-1/4"x1"	42.8	34.0	26.7	6.10	55.3	17.0	47.0
1-1/2"x1/2"	48.9	21.9	15.8	6.40	62.5	17.5	48.0
1-1/2"x3/4"	48.9	27.3	21.0	6.40	62.5	17.5	48.0
1-1/2"x1"	48.9	34.0	26.7	6.40	62.5	17.5	48.0
1-1/2"x1-1/4"	48.9	42.8	35.1	6.40	62.5	17.5	48.0
2"x1"	61.4	34.0	26.7	6.95	75.6	22.0	63.0
2"x1-1/4"	61.4	42.8	35.1	6.95	75.6	22.0	63.0
2"x1-1/2"	61.4	48.9	40.9	6.95	75.6	22.0	63.0
2-1/2"x1-1/4"	74.1	42.8	35.1	8.80	92.0	22.0	63.0
2-1/2"x1-1/2"	74.1	48.9	40.9	8.80	92.0	22.0	63.0
2-1/2"x2"	74.1	61.4	52.5	8.80	92.0	22.0	63.0
3"x1-1/2"	90.0	48.9	40.9	9.55	109.4	22.0	63.0
3"x2"	90.0	61.4	52.5	9.55	109.4	22.0	63.0
3"x2-1/2"	90.0	74.1	62.7	9.55	109.4	22.0	63.0
4"x2"	115.4	61.4	52.5	10.70	137.1	22.0	63.0
4"x2-1/2"	115.4	74.1	62.7	10.70	137.1	22.0	63.0
4"x3"	115.4	90.0	78.0	10.70	137.1	22.0	63.0

(1) Dimensions in accordance with ASME B16.11-2011.

## Couplet Socket Weld

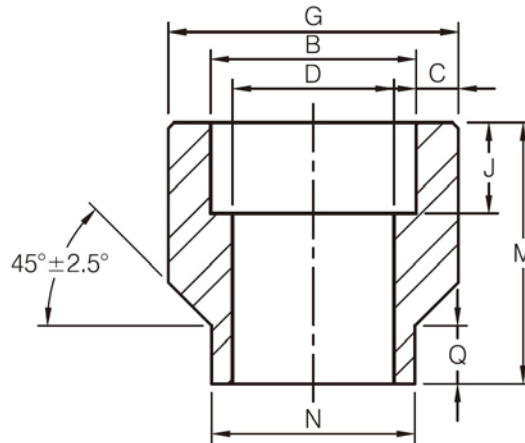

DN	Nom. Pipe Size	B	C <sup>(1)</sup>				D		J (Min)	N	Q	M	G	
			3M		6M		3M	6M					3M	6M
			Avg	Min	Avg	Min								
8	1/4"	14.2	3.78	3.30	4.60	4.01	9.3	6.4	9.5	17.5	9.5	30.2	23.8	25.4
10	3/8"	17.6	4.01	3.50	5.03	4.37	12.6	9.2	9.5	20.7	9.5	30.2	27.0	31.8
15	1/2"	21.8	4.67	4.09	5.97	5.18	15.8	11.8	9.5	23.8	9.5	33.4	33.4	38.1
20	3/4"	27.2	4.90	4.27	6.96	6.04	21.0	15.6	12.5	27.0	9.5	34.9	38.1	44.5
25	1"	33.9	5.69	4.98	7.92	6.93	26.7	20.7	12.5	33.4	9.5	42.9	46.1	57.2
32	1-1/4"	42.7	6.07	5.28	7.92	6.93	35.1	29.5	12.5	42.9	9.5	47.6	55.6	63.5
40	1-1/2"	48.8	6.35	5.54	8.92	7.80	40.9	34.0	12.5	49.2	9.5	50.8	63.5	76.2
50	2"	61.2	6.93	6.04	10.92	9.50	52.5	42.9	16.0	61.9	9.5	57.2	79.4	92.1
65	2-1/2"	73.9	8.76	7.67	-	-	62.7	-	16.0	73.0	9.5	63.5	92.1	-
80	3"	89.8	9.52	8.30	-	-	78.0	-	16.0	88.9	9.5	69.9	111.1	-
100	4"	115.2	10.69	9.35	-	-	102.3	-	19.0	114.3	9.5	76.2	141.3	-

- (1) Average of socket wall thickness around periphery shall be no less than listed values. The minimum values are permitted in localized areas.
- (2) 3M and 6M denote 3000Lb and 6000Lb.
- (3) Dimensions in accordance with ASME B16.11-2011.

## Cap Socket Weld

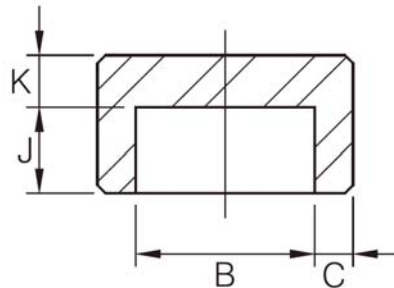

DN	Nom. Pipe Size	Socket Bore Dia. B	Bore Dia. Of Fitting D			Socket Wall Thickness C <sup>(1)</sup>						Depth of Socket (Min) J	End Wall Thickness (Min) K		
						3M		6M		9M			3M	6M	9M
			Avg	Min	Avg	Min	Avg	Min							
6	1/8"	10.8	6.9	4.0	-	3.18	3.18	3.96	3.43	-	-	9.5	4.8	6.4	-
8	1/4"	14.2	9.3	6.4	-	3.78	3.30	4.60	4.01	-	-	9.5	4.8	6.4	-
10	3/8"	17.6	12.6	9.2	-	4.01	3.50	5.03	4.37	-	-	9.5	4.8	6.4	-
15	1/2"	21.8	15.8	11.8	6.4	4.67	4.09	5.97	5.18	9.35	8.18	9.5	6.4	7.9	11.2
20	3/4"	27.2	21.0	15.6	11.1	4.90	4.27	6.96	6.04	9.78	8.56	12.5	6.4	7.9	12.7
25	1"	33.9	26.7	20.7	15.2	5.69	4.98	7.92	6.93	11.38	9.96	12.5	9.6	11.2	14.2
32	1-1/4"	42.7	35.1	29.5	22.8	6.07	5.28	7.92	6.93	12.14	10.62	12.5	9.6	11.2	14.2
40	1-1/2"	48.8	40.9	34.0	28.0	6.35	5.54	8.92	7.80	12.70	11.12	12.5	11.2	12.7	15.7
50	2"	61.2	52.5	42.9	38.2	6.93	6.04	10.92	9.50	13.84	12.12	16.0	12.7	15.7	19.0
65	2-1/2"	73.9	62.7	-	-	8.76	7.67	-	-	-	-	16.0	15.7	19.0	-
80	3"	89.8	78.0	-	-	9.52	8.30	-	-	-	-	16.0	19.0	22.4	-
100	4"	115.2	102.3	-	-	10.69	9.35	-	-	-	-	19.0	22.4	28.4	-

- (1) Average of socket wall thickness around periphery shall be no less than listed values. The minimum values are permitted in localized areas.
- (2) 3M, 6M and 9M denote 3000Lb, 6000Lb and 9000Lb.
- (3) Dimensions in accordance with ASME B16.11-2011.



## Reducer Insert Socket Weld

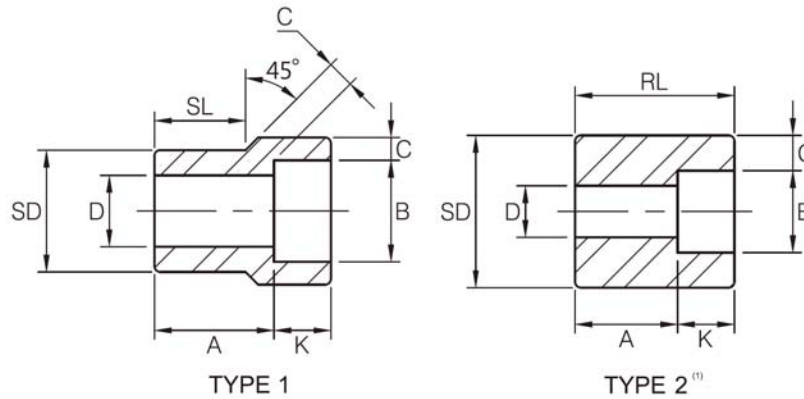

Nom. Pipe Size	Type		Socket		Shank Dia. SD	Laying Length A		Bore D		Wall (Min) C		Length			
	3M	6M	Dia. B	Depth (Min) K		3M	6M	3M	6M	3M	6M	SL		RL (Min)	
												3M	6M	3M	6M
3/8"x1/4"	1	1	14.35	10	17.15	19	21	9.0	6.5	3.78	4.60	14	16	-	-
1/2"x3/8"	1	1	17.78	10	21.34	21	23	12.5	9.0	4.01	5.03	16	16	-	-
1/2"x1/4"	1	1	14.35	10	21.34	21	21	9.0	6.5	3.78	4.60	16	16	-	-
3/4"x1/2"	1	1	21.97	10	26.67	22	25	16.0	11.5	4.67	5.97	17	19	-	-
3/4"x3/8"	2	1	17.78	10	26.67	16	22	12.5	9.0	4.01	5.03	-	19	27	-
3/4"x1/4"	2	2	14.35	10	26.67	18	22	9.0	6.5	3.78	4.60	-	-	27	32
1"x3/4"	1	1	27.31	13	33.40	24	28	21.0	15.5	4.90	6.96	19	21	-	-
1"x1/2"	2	1	21.97	10	33.40	16	28	16.0	11.5	4.67	5.97	-	21	28	-
1"x3/8"	2	2	17.78	10	33.40	18	22	12.5	9.0	4.01	5.03	-	-	28	33
1"x1/4"	2	2	14.35	10	33.40	19	24	9.0	6.5	3.78	4.60	-	-	28	33
1-1/4"x1"	1	1	34.04	13	42.16	25	30	26.5	20.5	5.69	7.92	21	22	-	-
1-1/4"x3/4"	2	2	27.31	13	42.16	18	21	21.0	15.5	4.90	6.96	-	-	32	35
1-1/4"x1/2"	2	2	21.97	10	42.16	19	22	16.0	11.5	4.67	5.97	-	-	32	35
1-1/4"x3/8"	2	2	17.78	10	42.16	21	24	12.5	9.0	4.01	5.03	-	-	32	35
1-1/4"x1/4"	2	2	14.35	10	42.16	22	25	9.0	6.5	3.78	4.60	-	-	32	35
1-1/2"x1-1/4"	1	1	42.80	13	48.26	28	35	35.0	29.5	6.07	7.92	22	25	-	-
1-1/2"x1"	2	1	34.04	13	48.26	18	29	26.5	20.5	5.69	7.92	-	25	33	-
1-1/2"x3/4"	2	2	27.31	13	48.26	19	25	21.0	15.5	4.90	6.96	-	-	33	40
1-1/2"x1/2"	2	2	21.97	10	48.26	21	27	16.0	11.5	4.67	5.97	-	-	33	40
1-1/2"x3/8"	2	2	17.78	10	48.26	22	28	12.5	9.0	4.01	5.03	-	-	33	40
2"x1-1/2"	1	1	48.90	13	60.32	32	39	41.0	34.0	6.35	8.90	25	28	-	-
2"x1-1/4"	2	2	42.80	13	60.32	21	24	35.0	29.5	6.07	7.92	-	-	38	41
2"x1"	2	2	34.04	13	60.32	22	25	26.5	21.0	5.69	7.92	-	-	38	41
2"x3/4"	2	2	27.31	13	60.32	24	27	21.0	15.5	4.90	6.96	-	-	38	41
2"x1/2"	2	2	21.97	10	60.32	25	28	16.0	11.5	4.67	5.97	-	-	38	41
2-1/2"x2"	1	1	61.37	16	73.02	46	43	52.5	43.0	6.93	10.92	32	38	-	-
2-1/2"x1-1/2"	2	2	48.90	13	73.02	35	35	41.0	34.0	6.35	-	-	-	54	54
2-1/2"x1-1/4"	2	2	42.80	13	73.02	37	37	35.0	29.5	6.07	-	-	-	54	54
2-1/2"x1"	2	2	34.04	13	73.02	38	38	26.5	21.0	5.69	-	-	-	54	54
2-1/2"x3/4"	2	2	27.31	13	73.02	40	38	21.0	15.5	4.90	-	-	-	54	54
3"x2-1/2"	1	1	74.07	16	88.90	38	57	62.5	54.0	8.76	-	32	45	-	-
3"x2"	2	2	61.37	16	88.90	25	32	52.5	43.0	6.93	-	-	-	48	54
3"x1-1/2"	2	2	48.90	13	88.90	29	32	41.0	34.0	6.35	-	-	-	48	54
3"x1-1/4"	2	2	42.80	13	88.90	30	32	35.0	29.5	6.07	-	-	-	48	54
3"x1"	2	2	34.04	13	88.90	32	32	26.5	21.0	5.69	-	-	-	48	54
4"x3"	2	-	90.04	16	114.30	33	-	78.0	-	9.50	-	-	-	60	-
4"x2-1/2"	2	-	74.07	16	114.30	38	-	62.5	-	8.76	-	-	-	60	-
4"x2"	2	-	61.37	16	114.30	38	-	52.5	-	6.93	-	-	-	60	-
4"x1-1/2"	2	-	48.90	13	114.30	42	-	41.0	-	6.35	-	-	-	60	-
4"x1-1/4"	2	-	42.80	13	114.30	43	-	35.0	-	6.07	-	-	-	60	-

- (1) At the option of the manufacturer Type 2 Reducers may be furnished in Type 1 configuration.
- (2) 3M and 6M denote 3000Lb and 6000Lb.
- (3) Dimensions in accordance with MSS SP-79-2011.

## Boss Socket Weld

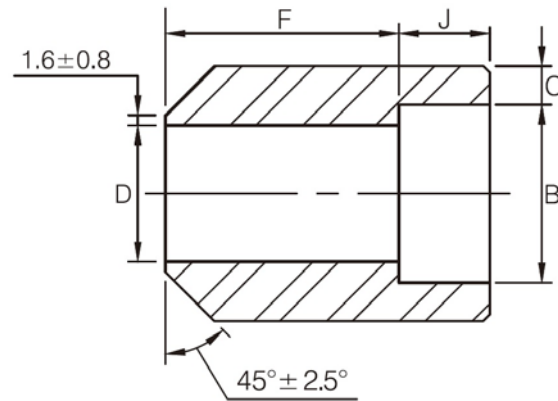

DN	Nom. Pipe Size	B (Min)	D		J (Min)		F		C (Min)	
			3000Lb	6000Lb	3000Lb	6000Lb	3000Lb	6000Lb	3000Lb	6000Lb
6	1/8"	10.7	6.8	-	10.0	-	28.0	-	3.2	-
8	1/4"	14.1	9.2	-	10.0	-	32.0	-	3.3	-
10	3/8"	17.6	12.5	-	11.0	-	34.0	-	3.5	-
15	1/2"	21.8	15.5	11.8	13.0	13.0	38.0	38.0	4.1	5.2
20	3/4"	27.4	21.0	15.5	13.0	13.0	38.0	38.0	4.3	6.1
25	1"	34.1	26.6	20.7	16.0	16.0	35.0	35.0	5.0	7.0
40	1-1/2"	49.0	40.5	34.0	19.0	19.0	32.0	32.0	5.6	7.8
50	2"	61.0	52.0	43.0	22.0	22.0	29.0	29.0	6.1	9.5
65	2-1/2"	73.8	62.0	54.0	22.0	22.0	29.0	29.0	7.7	10.4
80	3"	89.7	78.0	66.0	22.0	22.0	29.0	29.0	8.3	12.2

(1) Dimensions in accordance with BS3799-1974.

## Socket Weld Union

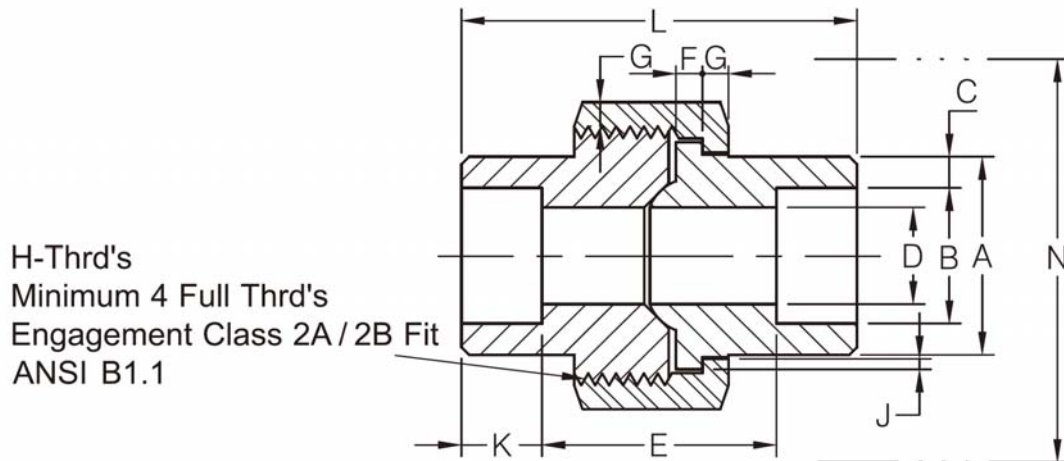

### 3000Lb

Nom. Pipe Size	Pipe End (Min) A	Socket Bore Dia. B <sup>(1)</sup>	Socket Wall (Min) C	Water Way Bore D <sup>(1)</sup>	Laying Length E <sup>(1)</sup>	Male Flange (Min) F	Nut (Min) G	Threads Per 25.4mm H	Bearing (Min) J	Depth of Socket (Min) K	Length Assem. Nom. L	Clear Assem. Nut N
1/8"	21.8	11.18 10.67	3.18	7.59 6.07	22.4 19.1	3.18	3.18	16	1.24	9.7	41.4	50.8
1/4"	21.8	14.61 14.10	3.30	10.01 8.48	22.4 19.1	3.18	3.18	16	1.24	9.7	41.4	50.8
3/8"	25.9	18.03 17.53	3.51	13.28 11.76	26.9 20.6	3.43	3.43	14	1.37	9.7	46.0	55.9
1/2"	31.2	22.23 21.73	4.09	16.56 15.04	26.9 20.6	3.68	3.68	14	1.50	9.7	49.0	58.4
3/4"	37.1	27.56 27.05	4.27	21.69 20.17	31.8 25.4	4.06	4.06	11	1.68	12.7	56.9	66.0
1"	45.5	34.29 33.78	4.98	27.41 25.88	34.3 26.2	4.57	4.45	11	1.85	12.7	62.0	78.7
1-1/4"	54.9	43.05 42.55	5.28	35.81 34.29	40.6 32.5	5.33	5.21	11	2.13	12.7	71.1	94.0
1-1/2"	61.5	49.15 48.64	5.54	41.66 40.13	42.2 34.0	5.84	5.59	10	2.31	12.7	76.5	111.8
2"	75.2	61.62 61.11	6.05	53.26 51.74	45.5 37.3	6.60	6.35	10	2.69	15.7	86.1	132.1
2-1/2"	91.7	74.45 73.81	7.67	64.24 61.19	61.7 52.1	7.49	7.11	8	3.07	15.7	102.4	149.9
3"	109.2	90.42 89.79	8.31	79.45 76.40	63.8 53.6	8.26	8.00	8	3.53	15.7	109.0	175.3

(1) Upper and lower values for each size are the respective maximum and minimum dimensions.

(2) Dimensions in accordance with MSS SP-83-2014.

## Socket Weld Union

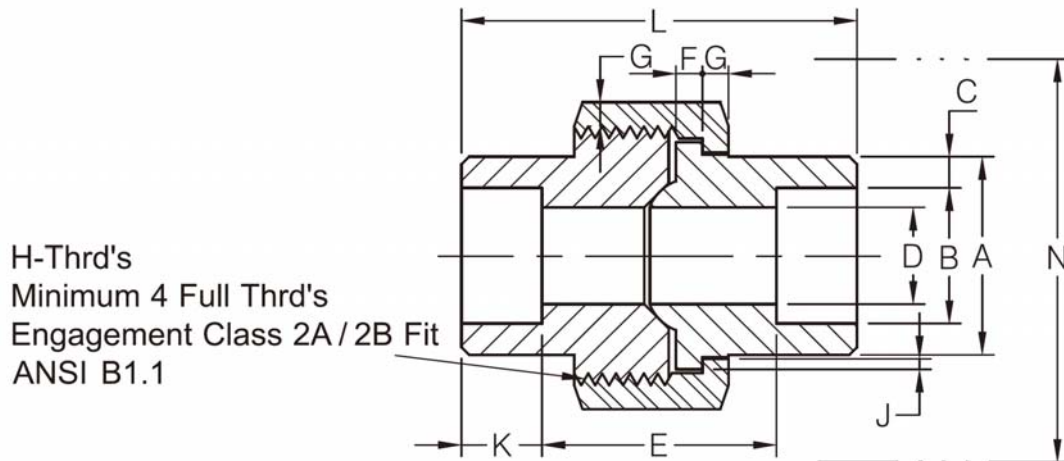

### 6000Lb

Nom. Pipe Size	Pipe End (Min) A	Socket Bore Dia. B <sup>(1)</sup>	Socket Wall (Min) C	Water Way Bore D <sup>(1)</sup>	Laying Length E <sup>(1)</sup>	Male Flange (Min) F	Nut (Min) G	Threads Per 25.4mm H	Bearing (Min) J	Depth of Socket (Min) K	Length Assem. Nom. L	Clear Assem. Nut N
1/8"	21.8	11.18 10.67	3.43	4.80 3.20	22.4 19.1	3.18	3.18	16	1.24	9.7	41.4	50.8
1/4"	25.9	14.61 14.10	4.01	7.11 5.59	26.9 20.6	3.43	3.43	14	1.37	9.7	46.0	55.9
3/8"	31.2	18.03 17.53	4.37	9.88 8.36	26.9 20.6	3.68	3.68	14	1.50	9.7	49.0	58.4
1/2"	37.1	22.23 21.72	5.18	12.55 11.02	31.8 25.4	4.06	4.06	11	1.68	9.7	56.9	66.0
3/4"	45.5	27.56 27.05	6.05	16.31 14.78	34.3 26.2	4.57	4.45	11	1.85	12.7	62.0	78.7
1"	54.9	34.29 33.78	6.93	27.41 25.88	40.6 32.5	5.33	5.21	11	2.13	12.7	71.1	94.0
1-1/4"	61.5	43.05 42.55	6.93	30.23 28.70	42.2 34.0	5.84	5.59	10	2.31	12.7	76.5	111.8
1-1/2"	75.2	49.15 48.64	7.80	34.75 33.22	45.5 37.3	6.60	6.35	10	2.69	12.7	86.1	132.1
2"	91.7	61.62 61.11	9.50	43.61 42.09	61.7 52.1	7.49	7.11	8	3.07	15.7	102.4	149.9
2-1/2"	109.2	74.45 73.81	10.39	54.74 53.21	63.8 53.6	8.26	8.00	8	3.53	15.7	109.0	175.3

(1) Upper and lower values for each size are the respective maximum and minimum dimensions.

(2) Dimensions in accordance with MSS SP-83-2014.

## Socket Weld 90° Branch Outlet

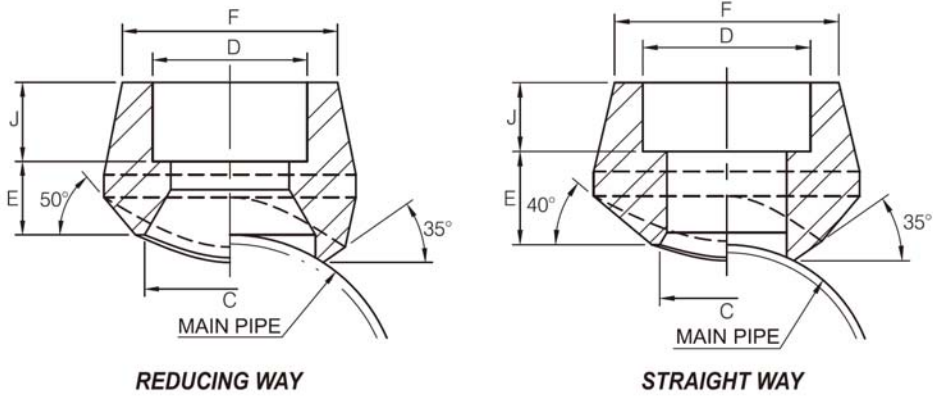

Outlet Pipe	Reducing Way									
	C		D		F		J (Min)		E (Max)	
	3M	6M	3M	6M	3M	6M	3M	6M	3M	6M
1/8"	13.7	-	10.8	-	22.0	-	9.5	-	11.0	-
1/4"	13.7	-	14.2	-	22.0	-	9.5	-	11.0	-
3/8"	19.1	-	17.6	-	25.9	-	9.5	-	13.0	-
1/2"	21.3	16.6	21.8	21.8	31.4	38.0	9.5	9.5	16.0	24.0
3/4"	26.7	21.2	27.2	27.2	37.1	44.0	12.5	12.5	16.0	26.0
1"	33.4	27.0	33.9	33.9	45.5	57.0	12.5	12.5	23.0	29.0
1-1/4"	42.2	35.8	42.7	42.7	57.0	64.0	12.5	12.5	23.0	31.0
1-1/2"	48.3	41.2	48.8	48.8	64.0	76.0	12.5	12.5	24.0	32.0
2"	60.3	51.6	61.2	61.2	76.0	92.0	16.0	16.0	24.0	37.0
2-1/2"	73.2	-	73.9	-	92.0	-	16.0	-	26.0	-
3"	88.9	-	89.8	-	109.2	-	16.0	-	31.0	-
4"	114.3	-	115.2	-	140.0	-	19.0	-	31.0	-

Outlet Pipe	Straight Way				
	C	D	F	J (Min)	E (Max)
	3000Lb				
1/8"	-	-	-	-	-
1/4"	11.5	14.2	22.0	9.5	11.0
3/8"	14.5	17.6	25.9	9.5	13.0
1/2"	16.5	21.8	31.4	9.5	16.0
3/4"	21.5	27.2	37.1	12.5	16.0
1"	27.2	33.9	45.5	12.5	23.0
1-1/4"	36.0	42.7	57.0	12.5	23.0
1-1/2"	42.0	48.8	64.0	12.5	24.0
2"	53.0	61.2	76.0	16.0	24.0
2-1/2"	65.0	73.9	92.0	16.0	26.0
3"	80.0	89.8	109.2	16.0	31.0
4"	104.0	115.2	140.0	19.0	31.0

### Conventional Run Size Combinations

		OUTLET SIZE										
		1/4"	3/8"	1/2"	3/4"	1"	1-1/4"	1-1/2"	2"	2-1/2"	3"	4"
RUN SIZE (Main Pipe)	Reducing way	3/8"~3/4" 1"~36"	1/2" 3/4"~1-1/4" 1-1/2"~36"	3/4" 1" 1-1/4" 1-1/2"~3" 3-1/2"~36"	1" 1-1/4" 1-1/2" 2"~3" 3-1/2"~6" 8"~36"	1-1/4" 1-1/2" 2" 2-1/2" 3" 3-1/2"~4" 5"~10" 12~36"	1-1/2" 2" 2-1/2" 3" 3-1/2"~5" 6"~8" 10" ~ 36"	2" 2-1/2" 3" 3-1/2" 4"~5" 6"~10" 12"~36"	2" 3" 3-1/2" 4" 5"~6" 8"~10" 12"~18" 20"~36"	3" 3-1/2" 4" 5" 6" 8" 10"~14" 16"~36"	3-1/2" 4" 5" 6" 8" 10" 12"~16" 18"~36"	5" 6" 8" 10" 12"~14" 16"~18" 20"~24" 26"~36"
	Straight way	3/8"~36"	1/2"~36"	3/4"~36"	1"~36"	1-1/4"~1-1/2" 2"~36"	1-1/2" 2"~3" 3-1/2"~36"	2" 2-1/2"~4" 5"~36"	2-1/2" 3" 3-1/2"~4" 5"~8" 8"~36"	3" 3-1/2"~4" 5"~8" 10"~36"	3-1/2" 4" 5" 6" 8"~12" 14"~36"	5" 6" 8" 10" 12"~16" 18"~36"

- (1) 3000LBS outlet size 4 and less fit a number of run pipe sizes and the fitting are marked accordingly.
- (2) Each charted outlet size is designed to fit a number of run pipe size.
- (3) 3M and 6M denote 3000Lb and 6000Lb.
- (4) Socket in accordance with ASME B16.11.
- (5) Dimensions in accordance with MSS SP-97-2012.

## Butt Weld 90° Branch Outlet

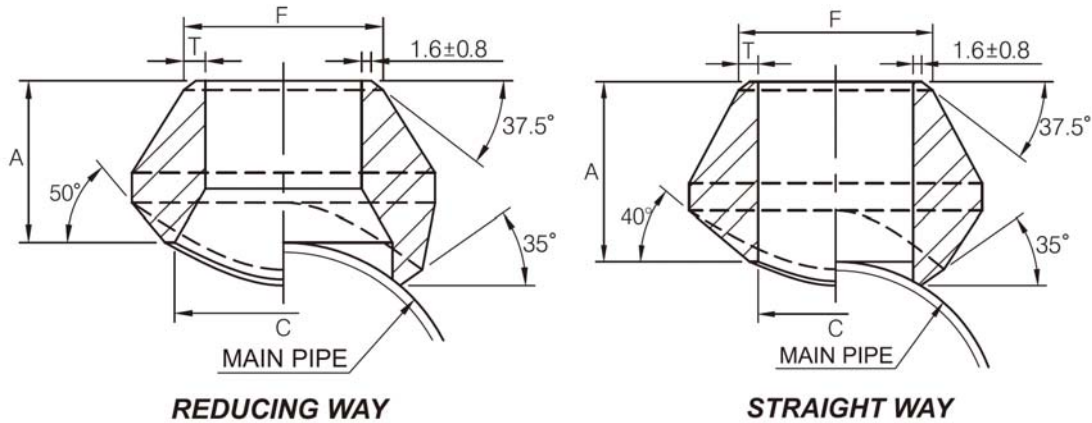

### Standard Weight and Extra Strong

Outlet Pipe	Reducing Way					
	A		C	F	T	
	Standard	Extra Strong			Standard	Extra Strong
1/8"	15.7	15.7	13.7	10.3	1.73	2.41
1/4"	15.7	15.7	13.7	13.7	2.24	3.02
3/8"	19.1	19.1	17.1	17.1	2.31	3.20
1/2"	19.1	19.1	21.3	21.3	2.77	3.73
3/4"	22.4	22.4	26.7	26.7	2.87	3.91
1"	26.9	26.9	33.4	33.4	3.38	4.55
1-1/4"	31.8	31.8	42.2	42.2	3.56	4.85
1-1/2"	33.3	33.3	48.3	48.3	3.68	5.08
2"	38.1	38.1	60.3	60.3	3.91	5.54
2-1/2"	41.1	41.1	73.0	73.0	5.16	7.01
3"	44.4	44.4	88.9	88.9	5.49	7.62
3-1/2"	47.8	47.8	101.6	101.6	5.74	8.56
4"	50.8	50.8	114.3	114.3	6.02	8.56
5"	57.2	57.2	141.3	141.3	6.55	9.53
6"	60.4	77.7	168.3	168.3	7.11	10.97
8"	69.8	98.6	219.3	219.3	8.11	12.70
10"	77.7	93.7	273.1	273.1	9.27	12.70
12"	85.9	103.1	323.9	323.9	9.53	12.70
14"	88.9	100.1	355.6	355.6	9.53	12.70
16"	93.7	106.2	406.4	406.4	9.53	12.70
18"	96.8	111.2	457.2	457.2	9.53	12.70
20"	101.6	119.1	508.0	508.0	9.53	12.70
24"	115.8	139.7	609.6	609.6	9.53	12.70

Outlet Pipe	Straight Way				
	A	C	F	T	
				Standard	Extra Strong
1/8"	-	-	-	-	-
1/4"	15.7	11.5	13.7	2.24	3.02
3/8"	19.1	14.5	17.1	2.31	3.20
1/2"	19.1	16.5	21.3	2.77	3.73
3/4"	22.4	21.5	26.7	2.87	3.91
1"	26.9	27.2	33.4	3.38	4.55
1-1/4"	31.8	36.0	42.2	3.56	4.85
1-1/2"	33.3	42.0	48.3	3.68	5.08
2"	38.1	53.0	60.3	3.91	5.54
2-1/2"	41.1	65.0	73.0	5.16	7.01
3"	44.4	80.0	88.9	5.49	7.62
3-1/2"	-	-	-	-	-
4"	50.8	104.0	114.3	6.02	8.56

## Butt Weld 90° Branch Outlet

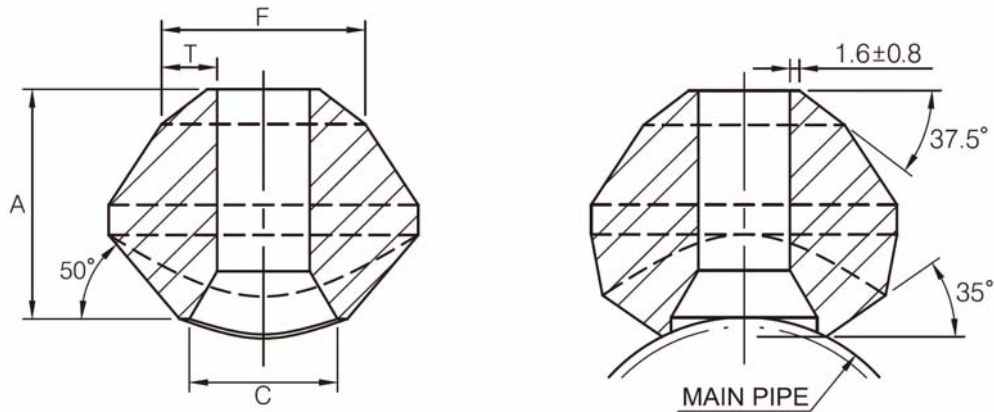

### Schedule 160 and Double Extra Strong

Outlet Pipe	A	C	F	T	
				SCH160	XXS
1/2"	28.4	13.8	21.3	4.78	7.47
3/4"	31.8	18.9	26.7	5.56	7.82
1"	38.1	24.3	33.4	6.35	9.09
1-1/4"	44.4	32.5	42.2	6.35	9.70
1-1/2"	50.8	38.1	48.3	7.14	10.15
2"	55.4	49.2	60.3	8.74	11.07
2-1/2"	62.0	59.0	73.0	9.53	14.02
3"	73.2	73.7	88.9	11.13	15.24
4"	84.1	97.2	114.3	13.49	17.12
5"	94.7	122.2	141.3	15.88	19.05
6"	104.6	146.4	168.3	18.26	21.95

### Conventional Run Size Combinations

		OUTLET SIZE										
		1/4"	3/8"	1/2"	3/4"	1"	1-1/4"	1-1/2"	2"	2-1/2"	3"	4"
RUN SIZE (Main Pipe)	Reducing way	3/8"~3/4" 1"~36"	1/2" 3/4"~1-1/4" 1-1/2"~36"	3/4" 1" 1-1/4" 1-1/2"~3" 3-1/2"~36"	1" 1-1/4" 1-1/2" 2"~3" 3-1/2"~6" 8"~36"	1-1/4" 1-1/2" 2" 2-1/2" 3" 3-1/2"~4" 5"~10" 12~36"	1-1/2" 2" 2-1/2" 3" 3-1/2"~5" 6"~8" 10"~36"	2" 2-1/2" 3" 3-1/2" 4"~5" 6"~10" 12"~36"	2-1/2" 3" 3-1/2" 4" 5"~6" 8"~10" 12"~18" 20"~36"	3" 3-1/2" 4" 5" 6" 8" 10"~14" 16"~36"	3-1/2" 4" 5" 6" 8" 10" 12"~16" 18"~36"	5" 6" 8" 10" 12"~14" 16"~18" 20"~24" 26"~36"
	Straight way	3/8"~36"	1/2"~36"	3/4"~36"	1"~36"	1-1/4"~1-1/2" 2"~36"	1-1/2" 2"~3" 3-1/2"~36"	2" 2-1/2"~4" 5"~36"	2-1/2" 3"~3-1/2" 4"~6" 8"~36"	3" 3-1/2"~4" 5"~8" 10"~36"	3-1/2" 4" 5" 6" 8"~12" 14"~36"	5" 6" 8" 10" 12"~16" 18"~36"

- (1) Each charted outlet size is designed to fit a number of run pipe size.
- (2) Outlet size 4 and less for Standard and Extra Strong fit a number of run pipe sizes and the fitting are marked accordingly.
- (3) Outlet size 5 and up and Schedule 160 and Double Extra Strong order to specific size combination.
- (4) Weld Bevel in accordance with ASME B16.25.
- (5) Dimensions in accordance with MSS SP-97-2012.



## Socket Weld 45° Branch Outlet

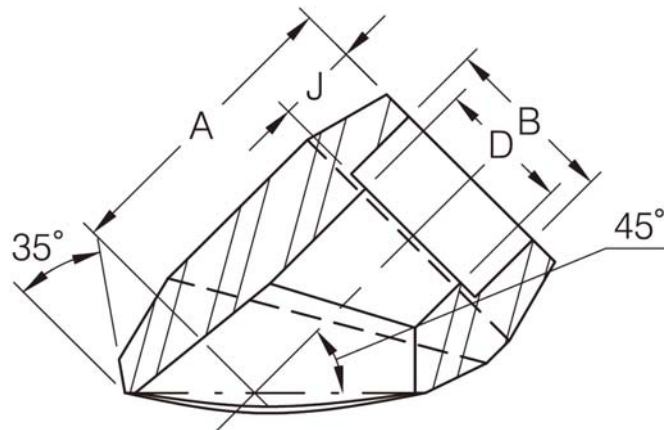

Outlet Pipe		A				B	D		J (Min)
DN	Inch	3000Lb		6000Lb			3000Lb	6000Lb	
		Min	Max	Min	Max				
8	1/4"	38.1	42.9	38.9	47.6	14.2	9.3	6.4	9.5
10	3/8"	38.1	42.9	38.9	47.6	17.6	12.6	9.2	9.5
15	1/2"	38.1	44.5	46.0	55.6	21.8	15.8	11.8	9.5
20	3/4"	46.0	50.8	54.0	63.5	27.2	21.0	15.6	12.5
25	1"	54.0	63.5	61.1	73.0	33.9	26.7	20.7	12.5
32	1-1/4"	61.1	76.2	65.1	77.8	42.7	35.1	29.5	12.5
40	1-1/2"	63.5	76.2	78.6	85.7	48.8	40.9	34.0	12.5
50	2"	76.2	84.1	78.6	104.8	61.2	52.5	42.9	16.0

- (1) Socket weld in accordance with ASME B16.11.
- (2) Dimensions in accordance with MSS SP-97-2012.



## Butt Weld 45° Branch Outlet

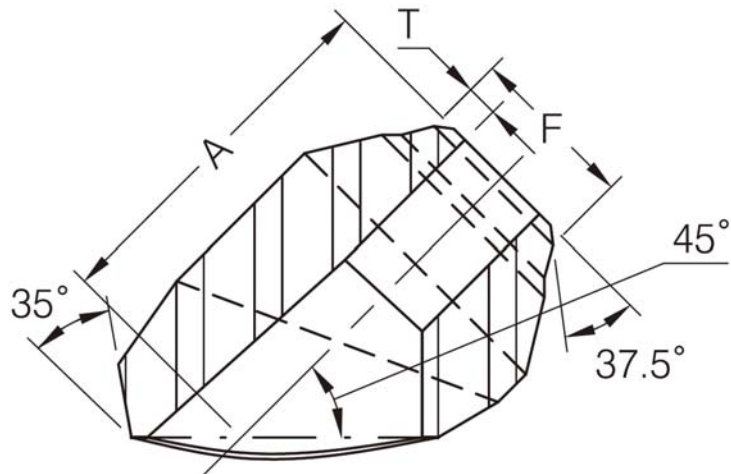

Outlet Pipe		A		T		F
DN	Inch	Min	Max	Sch 40/STD	Sch 80/XS	
8	1/4"	38.1	42.9	2.24	3.02	13.7
10	3/8"	38.1	42.9	2.31	3.20	17.1
15	1/2"	38.1	42.9	2.77	3.73	21.3
20	3/4"	44.5	50.8	2.87	3.91	26.7
25	1"	54.0	65.1	3.38	4.55	33.4
32	1-1/4"	54.0	65.1	3.56	4.85	42.2
40	1-1/2"	63.5	69.9	3.68	5.08	48.3
50	2"	73.0	88.9	3.91	5.54	60.3

- (1) Wall thickness (T) in accordance with ASME B16.10M, ASME B36.19M.  
 (2) Dimensions in accordance with MSS SP-97-2012.

## Socket Weld 90° Elbow Outlet

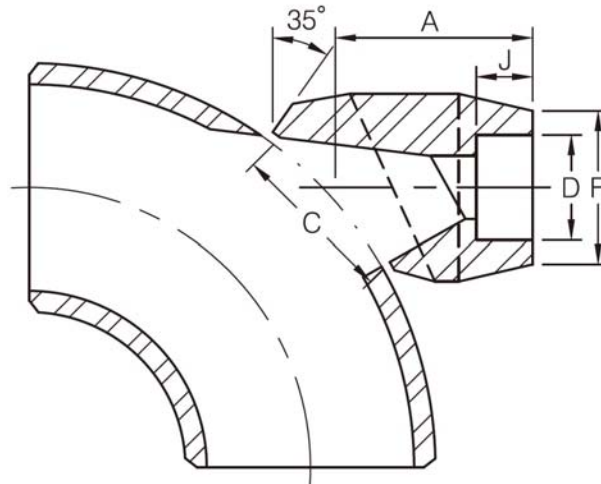

Outlet Pipe		A		C		F		D	J	
DN	Inch	3000Lb	6000Lb	3000Lb	6000Lb	3000Lb	6000Lb		3000Lb	6000Lb
8	1/4"	40.5	40.5	35.2	34.9	22.0	26.0	14.35	10.0	10.0
10	3/8"	40.5	40.5	35.2	34.9	25.9	33.0	17.80	10.0	10.0
15	1/2"	40.5	47.6	35.2	34.9	31.4	38.0	21.95	11.1	10.0
20	3/4"	47.6	55.6	43.6	43.6	37.1	44.0	27.30	12.7	14.3
25	1"	55.6	60.3	54.0	54.0	45.5	57.0	34.05	13.5	15.9
32	1-1/4"	60.3	66.7	67.5	67.5	57.0	64.0	42.80	15.1	20.6
40	1-1/2"	66.7	85.7	76.2	76.2	64.0	76.0	48.90	15.9	20.6
50	2"	81.0	-	104.8	-	76.0	-	61.35	17.5	-
65	2-1/2"	82.6	-	106.4	-	92.0	-	74.15	23.8	-
80	3"	96.8	-	125.4	-	109.2	-	90.10	28.6	-
100	4"	114.3	-	163.5	-	140.0	-	115.75	29.4	-

(1) Socket weld in accordance with ASME B16.11.

## Butt Weld 90° Elbow Outlet

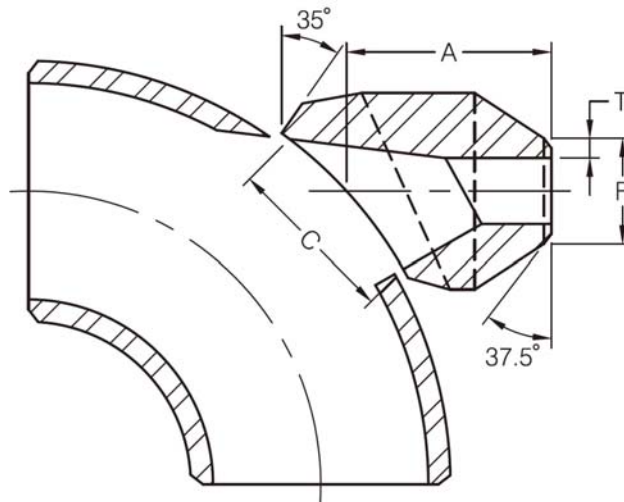

Outlet Pipe		A		C	F	T	
DN	Inch	Sch80	Sch160			Sch80	Sch160
8	1/4"	40.5	40.5	35.2	13.7	3.0	3.7
10	3/8"	40.5	40.5	35.2	17.1	3.2	4.0
15	1/2"	40.5	47.6	35.2	21.3	3.7	4.7
20	3/4"	47.6	55.6	43.6	26.7	3.9	5.5
25	1"	55.6	60.3	54.0	33.4	4.5	6.4
32	1-1/4"	60.3	67.7	67.5	42.2	4.9	6.4
40	1-1/2"	66.7	85.7	76.2	48.3	5.1	7.1
50	2"	81.0	-	104.8	60.3	5.5	-
65	2-1/2"	82.6	-	106.4	73.0	7.0	-
80	3"	96.8	-	125.4	88.9	7.6	-
100	4"	114.3	-	163.5	114.3	8.6	-

(1) Weld bevel in accordance with ASME B16.25.

## Nipple Branch Outlet Butt Weld (Bevel / Plain End)

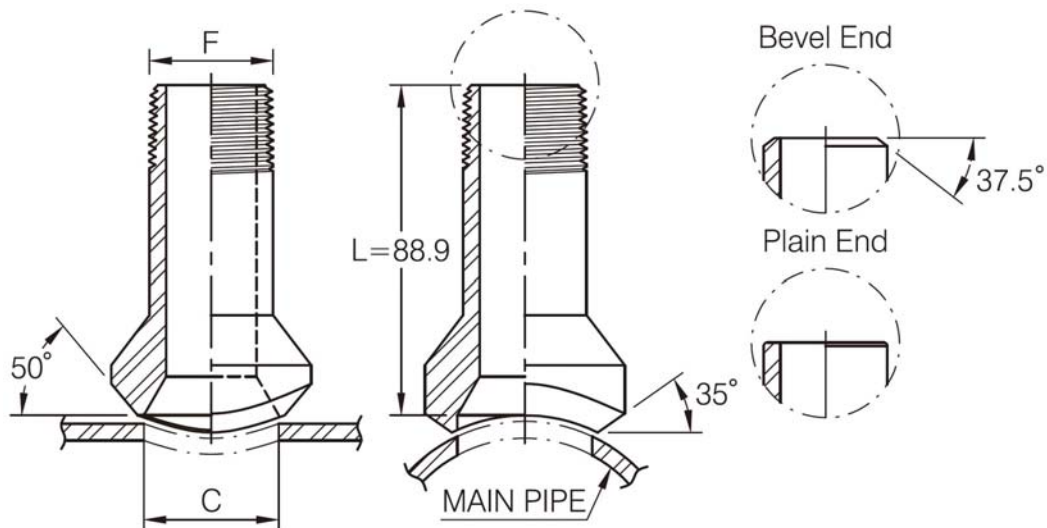

Outlet Pipe	C		F
	3000LB - XS	6000LB - S160	
1/2"	23.8	13.8	21.3
3/4"	30.2	18.9	26.7
1"	36.5	24.3	33.4
1-1/4"	44.5	32.5	42.2
1-1/2"	50.8	38.1	48.3
2"	65.1	49.2	60.3

- (1) Range: Sch40, STD, Sch80, XS, Sch160, XXS.
- (2) Weld bevel in accordance with ASME B16.25.

## Dimensional Tolerance of ASME B16.11

Item	Type of pipe Fitting	Nominal diameter				
		DN	6 to 8	10 to 20	25 to 50	65 to 100
		NPS	1/8 to 1/4	3/8 to 3/4	1 to 2	2-1/2 to 4
Bore diameter of socket (B)	All types of Pipe Fitting	+ 0.4 - 0			+ 0.5 - 0	
Bore diameter of fitting (D)		± 0.7			± 1.4	
Concentricity of bore (X)		± 0.8				
Coin cadence of axes (Y)		1 / 200 Max				
Center to bottom of socket (A)	45, 90D Elbow, Tee, Cross	± 1.0	± 1.5	± 2.0	± 2.5	
Bottom to bottom of socket (E)	Full Coupling	± 1.5	± 3.0	± 4.0	± 5.0	
Bottom of socket to opposite face (F)	Half Coupling	± 1.0	± 1.5	± 2.0	± 2.5	

Unit : mm

## Dimensional Tolerance of BS3799

Item	Type of pipe Fitting	Nominal diameter				
		DN	6 to 8	10 to 20	25 to 50	65 to 80
		NPS	1/8 to 1/4	3/8 to 3/4	1 to 2	2-1/2 to 3
Concentricity of bore (X)	All types of Pipe Fitting	± 0.8				
Coin cadence of axes (Y)		1 / 200 Max				
Bore diameter of fitting (b)	Boss, Hex Nipple	± 0.4			± 0.8	
Bottom of socket to opposite face	Boss	± 0.8	± 1.5	± 2.0	± 2.5	

Unit : mm

## Weight List

### Threaded Fittings

Size Product (Lbs)		1/8"	1/4"	3/8"	1/2"	3/4"	1"	1-1/4"	1-1/2"	2"	2-1/2"	3"	4"
		2000	0.1	0.08	0.13	0.25	0.35	0.53	0.82	1.06	1.7	3.14	4.81
90 Elbow	3000	0.1	0.14	0.29	0.43	0.69	1.14	1.42	2.63	2.92	5.99	8.88	14.85
	6000	0.17	0.33	0.45	0.8	1.31	1.61	2.93	3.79	7.31	9.88	17.73	15.76
45 Elbow	2000	0.09	0.08	0.1	0.2	0.27	0.41	0.68	0.82	1.41	3.46	5.44	8.96
	3000	0.09	0.12	0.24	0.34	0.56	0.94	1.03	2.05	2.23	3.71	5.97	8.96
	6000	0.11	0.27	0.39	0.63	1.07	1.27	2.24	2.54	4.37	7.01	14.16	11.36
Tee	2000	0.13	0.12	0.17	0.31	0.43	0.69	1.07	1.39	2.16	4.11	6.12	14.74
	3000	0.13	0.2	0.38	0.56	0.92	1.49	1.76	3.27	3.53	6.99	10.19	19.13
	6000	0.2	0.45	0.63	0.98	1.65	2.17	3.74	4.71	7.88	13.11	21.7	18.53
Cross	2000	0.17	0.14	0.21	0.39	0.54	0.83	1.26	1.75	2.65	5.26	7.58	16.35
	3000	0.17	0.26	0.44	0.72	1.06	1.79	2.13	3.93	4.27	8.51	12.45	21.93
Full Coupling	3000	0.05	0.04	0.06	0.13	0.19	0.45	0.81	1.07	1.4	2.29	3.38	6.28
	6000	0.08	0.13	0.2	0.34	0.5	0.87	1.09	1.94	2.87	4.2	6.1	10.04
Half Coupling	3000	0.02	0.02	0.03	0.06	0.1	0.23	0.34	0.54	0.7	1.13	1.68	3.11
	6000	0.07	0.06	0.09	0.16	0.24	0.45	0.55	0.96	1.7	2.1	3.05	5.02
Red Coupling	3000	0.05	0.05	0.06	0.13	0.19	0.39	0.68	0.99	1.37	2.07	3.08	5.44
	6000	0.08	0.06	0.18	0.31	0.41	0.85	1.05	1.81	3.4	4.2	6.1	10.04
Cap	3000	0.02	0.04	0.05	0.11	0.18	0.37	0.62	0.72	1.09	2.22	3.5	4.84
	6000	0.06	0.06	0.09	0.26	0.4	0.71	0.59	0.77	2.23			
Street Elbow	3000	0.13	0.11	0.22	0.31	0.53	1.02	1.13	2.01	2.91			
Union	3000	0.28	0.28	0.24	0.34	0.48	0.77	1.03	1.63	2.43	3.63	5.27	12
Hex. Nipple	3000	0.03	0.04	0.05	0.09	0.15	0.47	0.45	0.62	1.03	1.51	2.22	4
Square Head Plug		0.01	0.01	0.03	0.05	0.09	0.16	0.27	0.38	0.63	0.96	1.53	3.83
Hex. Head Plug		0.01	0.03	0.05	0.07	0.14	0.22	0.44	0.59	1.03	1.8	2.6	5.2
Round Head Plug		0.02	0.45	0.07	0.12	0.2	0.34	0.55	0.79	1.47	2.34	3.26	6.24
Hex. Head Bushing			0.01	0.01	0.03	0.05	0.09	0.25	0.34	0.45	0.6	1.16	3.2

Unit: kgs

### Socket Weld Fittings

Size Product (Lbs)		1/8"	1/4"	3/8"	1/2"	3/4"	1"	1-1/4"	1-1/2"	2"	2-1/2"	3"	4"
		3000	0.09	0.08	0.12	0.22	0.33	0.53	0.84	1.08	1.68	3.2	5.38
90 Elbow	6000	0.1	0.15	0.29	0.4	0.73	1.17	1.48	2.79	3.28			
	3000	0.08	0.07	0.11	0.2	0.28	0.42	0.69	0.8	1.35	2.53	5.1	9.41
45 Elbow	6000	0.09	0.14	0.26	0.36	0.57	0.92	1.11	2.01	2.09			
	3000	0.13	0.09	0.15	0.29	0.42	0.65	1.04	1.35	2.04	3.98	5.9	13.92
Tee	6000	0.14	0.2	0.43	0.56	0.94	1.49	1.93	3.37	3.95			
	3000	0.16	0.13	0.2	0.35	0.47	0.73	1.12	1.58	2.25	4.37	6.69	14.58
Cross	6000	0.17	0.26	0.45	0.67	1.07	1.75	2.26	3.96	4.42			
	3000	0.04	0.05	0.07	0.13	0.17	0.29	0.45	0.59	0.86	1.4	1.78	2.85
Full Coupling	6000	0.05	0.07	0.114	0.204	0.27	0.44	0.6	1.11	1.62			
	3000	0.04	0.05	0.07	0.13	0.21	0.3	0.34	0.66	1.09	1.63	2.1	3.71
Half Coupling	6000	0.06	0.09	0.12	0.21	0.31	0.51	0.75	1.25	1.92			
	3000	0.04	0.05	0.07	0.13	0.19	0.27	0.49	0.59	0.97	1.42	1.88	3.31
Red Coupling	6000				0.24	0.33	0.65	0.75	1.2	2.12			
	3000	0.03	0.04	0.07	0.1	0.16	0.25	0.45	0.59	0.96	1.43	2.74	4.24
Cap	6000	0.05	0.08	0.1	0.16	0.23	0.36	0.64	0.94	1.41			
	3000	0.28	0.28	0.25	0.35	0.49	0.81	1.1	1.61	2.16	3.5	5.15	11.59

Unit: kgs